



Streamline

Electric Solar Ready Water Heater



Owner's Guide and Installation Instructions



WARNING: Plumber – Be Aware – Solar Installation
Use copper pipe ONLY. Plastic pipe MUST NOT be used.
It is a requirement of a solar water heater installation that all pipe work be in copper and not plastic, due to the effects of high water temperatures and pressures.

This water heater must be installed and serviced by a qualified person.
Please leave this guide with the householder.



WARNING: Plumber – Be Aware – Solar Installation

- The solar hot and solar cold pipes between the solar storage tank and the solar collectors **MUST BE** of copper. All compression fittings must use brass or copper olives.
- The full length of the solar hot and solar cold pipes **MUST BE** insulated.

The insulation must:

- be of a closed cell type or equivalent, suitable for a solar water heating application and capable of withstanding the temperature of the water generated by the solar collectors under stagnation conditions

The specification of the chosen insulation material should be checked with the insulation manufacturer prior to installation as different materials may vary in temperature tolerance.

- be at least 13 mm thick
- be weatherproof and UV resistant if exposed
- extend through any penetrations in the eaves, ceiling and roof
- cover valves and fittings in the solar pipe work
- be fitted up to and cover the connections on both the solar storage tank and the solar collectors.

Note: Failure to observe these requirements also increases the risk of freeze damage.

Uninsulated pipe work, including concealed in cavities and roof spaces or where it may be in contact with a metal roof, may lead to freeze damage. There is NO WARRANTY for freeze damage if the solar hot and solar cold pipes are not insulated in accordance with the installation instructions.

The insulation is essential to assist in providing freeze protection, will offer protection to a metal roof against corrosion due to water running off the copper pipes, assist in avoiding accidental contact with the solar pipe work as very high temperature water can flow from the solar collectors to the solar storage tank, and also reduce pipe heat losses.

- The insulated copper pipe work:
 - should be fixed at suitable locations to prevent or reduce the possibility of noise from water hammer and vibration from occurring
 - is not to be placed or installed in contact with plastic pipe work.

Likewise, plastic pipe work is not to be placed or installed in contact with the insulated copper pipe work after the collector circuit is installed.

- Plastic pipe **MUST NOT** be used, as it will not withstand the temperature and pressure of the water generated by the solar collectors under stagnation conditions. Extremely high water temperatures of up to 150°C for non-selective surface collectors and greater than 200°C for selective surface collectors and high water pressures exceeding 1000 kPa can be generated under these conditions. Plastic pipe cannot withstand these temperatures and pressures and **MUST NOT** be used. Failure of plastic pipe can lead to the release of high temperature water and cause severe water damage and flooding.

Plumber: It is important to refer to and read in full the complete
“Warning: Plumber – Be Aware” statement commencing on page 52.

An electronic copy of these Owner’s Guide and Installation Instructions can be downloaded from solahart.com.au.

PATENTS

This water heater may be protected by one or more patents or registered designs in the name of Solahart Industries Pty Ltd or Rheem Australia Pty Ltd.

TRADE MARKS

® Registered trademark of Solahart Industries Pty Ltd or Rheem Australia Pty Ltd.
™ Trademark of Solahart Industries Pty Ltd or Rheem Australia Pty Ltd.

Note: Every care has been taken to ensure accuracy in preparation of this publication.
No liability can be accepted for any consequences, which may arise as a result of its application.

CONTENTS

HOUSEHOLDER

This booklet contains important information about your new water heater, including terms of the Solahart warranty.

We recommend you read pages 7 to 29, and the terms of the Solahart warranty on pages 4 to 6.

The other pages are intended for the installer but may be of interest.

Warranty	4
Safety, Warnings, Installation Notes	7
About Your Water Heater	10
How Your Electric Water Heater Works	13
How Your Solar Water Heater Works	14
Maintenance Requirements.....	20
Water Supplies.....	22
Save A Service Call	25
Installation – Water Heater	30
Installation – Solar Control Unit.....	42
Installation – Solar Collectors.....	47
Connections – Plumbing	54
Connections – Electrical.....	58
Commissioning.....	63
Draining The Electric Water Heater	67
Draining The Solar Storage Tank.....	67
Draining The Solar Collectors.....	68
Purging And Flushing The Solar Collectors.....	69
Solahart Installation Report	73
Solahart Offices	76

SOLAHART ELECTRIC AND STREAMLINE OPEN CIRCUIT SOLAR WATER HEATER WARRANTY – AUSTRALIA ONLY

SOLAR ELECTRIC AND STREAMLINE OPEN CIRCUIT WATER HEATER MODELS 270RMX, 320RMX

1. THE SOLAHART WARRANTY – GENERAL

- 1.1 This warranty is given by Solahart Industries Pty Limited ABN 45 064 945 848 of 1 Alan Street, Rydalmere New South Wales.
- 1.2 Solahart offers national service through its Dealer network. Solahart will repair or replace components at the address of the water heater subject to the terms of the Solahart warranty. Solahart, in addition can provide preventative maintenance and advice on the operation of your water heater.
- 1.3 For details about this warranty, you can contact us on 1800 638 011.
- 1.4 The terms of this warranty and what is covered by it are set out in sections 2 and 3 and apply to water heaters manufactured from 1st March 2021.
- 1.5 If a subsequent version of this warranty is published, the terms of that warranty and what is covered by it will apply to water heaters manufactured after the date specified in the subsequent version.

2. TERMS OF THE SOLAHART WARRANTY AND EXCLUSIONS TO IT

- 2.1 Solahart may reject a claim under this warranty in its sole discretion if:
 - a) You do not arrange for a major service to be conducted on your water heater in the fifth year after installation, in accordance with Solahart's recommendation in the Owner's Guide and Installation Instructions; and
 - b) The fault giving rise to the warranty claim would have been detected and rectified during that major service.
 - 2.2 The decision of whether to repair or replace a faulty component is at Solahart's sole discretion.
 - 2.3 If you require a call out and we find that the fault is not covered by the Solahart warranty, you are responsible for our standard call out charge. If you wish to have the relevant component repaired or replaced by Solahart, that service will be at your cost.
 - 2.4 Where a failed component or cylinder is replaced under this warranty, the balance of the original warranty period will remain effective. The replacement does not carry a new Solahart warranty.
 - 2.5 Where the water heater is installed outside the boundaries of a metropolitan area as defined by Solahart or further than 30 km from a regional Solahart Dealer, the cost of transport, insurance and travelling between the nearest Solahart Dealer's premises and the installed site shall be the owner's responsibility.
 - 2.6 Where the water heater is installed in a position that does not allow safe or ready access, the cost of that access, including the cost of additional materials handling and/or safety equipment, shall be the owner's responsibility. In other words, the cost of dismantling or removing cupboards, doors or walls and the cost of any special equipment to bring the water heater to floor or ground level or to a serviceable position is not covered by this warranty.
 - 2.7 This warranty only applies to the original and genuine Solahart water heater in its original installed location and any genuine Solahart replacement parts.
 - 2.8 The Solahart warranty does not cover faults that are a result of:
 - a) Accidental damage to the water heater or any component (for example: (i) Acts of God such as floods, storms, fires, lightning strikes and the like; and (ii) third party acts or omissions).
 - b) Misuse or abnormal use of the water heater.
 - c) Installation not in accordance with the Owner's Guide and Installation Instructions or with relevant statutory and local requirements in the State or Territory in which the water heater is installed.
 - d) Connection at any time to a water supply that does not comply with the water supply guidelines as outlined in the Owner's Guide and Installation Instructions.
 - e) Repairs, attempts to repair or modifications to the water heater by a person other than the Solahart Dealer or a Solahart Accredited Service Agent.
 - f) Faulty plumbing or faulty power supply.
 - g) Failure to maintain the water heater in accordance with the Owner's Guide and Installation Instructions.
 - h) Transport damage.
 - i) Fair wear and tear from adverse conditions (for example, corrosion).
-

SOLAHART ELECTRIC AND STREAMLINE OPEN CIRCUIT SOLAR WATER HEATER WARRANTY – AUSTRALIA ONLY

SOLAR ELECTRIC AND STREAMLINE OPEN CIRCUIT WATER HEATER MODELS 270RMX, 320RMX

- j) Cosmetic defects.
 - k) Breakage of collector glass for any reason including hail damage (we suggest that the collector glass be covered by your home insurance policy).
 - l) Ice formation in the waterways of a solar water heater system utilising a solar storage tank with a frost element and incorporating a freeze protection system where the electricity supply has been switched off or has failed or where it is installed at an altitude more than 600 metres above sea level.
- 2.9 Solahart may reject a claim under this warranty in its sole discretion if a third party solar diverter is connected to the water heater.
- 2.10 Subject to any statutory provisions to the contrary, this warranty excludes any and all claims for:
- a) Damage to furniture, carpet, walls, foundations or any other consequential loss either directly or indirectly due to leakage from the water heater, or due to leakage from fittings and/ or pipe work of metal, plastic or other materials caused by water temperature, workmanship or other modes of failure, and
 - b) Loss or damage due to the water heater if it is not connected to or loses connectivity to the internet.

3. WHAT IS COVERED BY THE SOLAHART WARRANTY FOR THE WATER HEATERS DETAILED IN THIS DOCUMENT

- 3.1 Solahart will repair or replace a faulty component of your water heater if it fails to operate in accordance with its specifications as follows:

What components are covered	The period from the date of installation of the particular component in which the fault must appear in order to be covered	What coverage you receive
-----------------------------	----------------------------------------------------------------------------------------------------------------------------	---------------------------

Electric and Streamline RMX Models

All components (all installations)	Year 1	Repair and / or replacement of the faulty component, free of charge, including labour.
All components (only if the water heater is installed in a single-family domestic dwelling)	Year 2	Repair and / or replacement of the faulty component, free of charge, including labour.
The cylinder and solar collectors (if the water heater is installed in a single-family domestic dwelling)	Year 3	Repair and / or replacement of the cylinder or solar collector, free of charge, including labour.
	Years 4 to 10	Replacement cylinder or solar collector, free of charge. Installation and repair labour costs are the responsibility of the owner.
The cylinder and solar collectors (if the water heater is <u>not</u> installed in a single-family domestic dwelling)	Years 2 & 3	Replacement cylinder or solar collector, free of charge. Installation and repair labour costs are the responsibility of the owner.

- 3.2 Various components of your water heater may be installed at different times. In particular, an upgrade to a solar water heater (with the installation of the solar collectors and solar controller unit) or to a Grid Interactive electric water heater (with the installation of the control module package and energy management unit) may occur sometime after the installation of the original electric water heater. Please note that:
- a) The warranty period shown in the table in Clause 3.1 for each component starts from the date that particular component is first installed.
 - b) The subsequent installation of an additional component (when the original electric water heater is upgraded to a solar water heater or a Grid Interactive electric water heater) does not affect or extend the warranty period for the existing components of the original electric water heater installation.

SOLAHART ELECTRIC AND STREAMLINE OPEN CIRCUIT SOLAR WATER HEATER WARRANTY – AUSTRALIA ONLY

SOLAR ELECTRIC AND STREAMLINE OPEN CIRCUIT WATER HEATER MODELS 270RMX, 320RMX

- 3.3 Without limiting the periods shown in the table in Clause 3.1, a 5-year whole-of-product warranty applies where a rebate has been received under Solar Victoria's Solar Homes Program for a water heater installed from the 1st July 2023. For further details, call 131 031. Proof of receipt of the rebate is required to be produced at the time of the service call.

4. ENTITLEMENT TO MAKE A CLAIM UNDER THIS WARRANTY

- 4.1 To be entitled to make a claim under this warranty you need to:
- a) Be the owner of the water heater or have consent of the owner to act on their behalf.
 - b) Contact Solahart without undue delay after detection of the defect and, in any event, within the applicable warranty period.
- 4.2 You are not entitled to make a claim under this warranty if your water heater:
- a) Does not have its original serial numbers or rating labels.
 - b) Is not installed in Australia.

5. HOW TO MAKE A CLAIM UNDER THIS WARRANTY

- 5.1 If you wish to make a claim under this warranty, you need to:
- a) Contact Solahart on 1800 638 011 and provide owner's details, address of the water heater, a contact number and date of installation of the water heater or if that's unavailable, the date of manufacture and serial number (from the rating label on the water heater).
 - b) Solahart will arrange for the water heater to be tested and assessed on-site.
 - c) If Solahart determines that you have a valid warranty claim, Solahart will repair or replace the water heater in accordance with this warranty.
- 5.2 Any expenses incurred in the making of a claim under this warranty will be borne by you.

6. THE AUSTRALIAN CONSUMER LAW

- 6.1 Our goods come with guarantees that cannot be excluded under the Australian Consumer Law. You are entitled to a replacement or refund for a major failure and for compensation for any other reasonably foreseeable loss or damage. You are also entitled to have the goods repaired or replaced if the goods fail to be of acceptable quality and the failure does not amount to a major failure.
- 6.2 The Solahart warranty (set out above) is in addition to any rights and remedies that you may have under the Australian Consumer Law.

7. REPAIR NOTICE UNDER THE AUSTRALIAN CONSUMER LAW

- 7.1 Goods presented for repair may be replaced by refurbished goods of the same type rather than being repaired. Refurbished parts may be used to repair the goods.

SAFETY, WARNINGS, INSTALLATION NOTES

It is important you read the following **Safety and Warnings**, and **Relief Valves** information.

If the solar water heater is installed with an in-series booster water heater, it is also important you read the Safety and Warnings, and Relief Valves information relating to the function and operation of the in-series water heater. Refer to the Owner's Guide and Installation Instructions supplied with the in-series water heater.

⚠ SAFETY AND WARNINGS

- When installed as an electric water heater, the water heater will operate until a water temperature of 60°C to 70°C is reached, depending upon the thermostat setting.

When installed as a solar water heater, the circulator will operate whilst suitable solar conditions are available until water in the solar storage tank is heated to 70°C to 75°C during normal operation. Water temperature of up to 75°C to 80°C could be reached during over-temperature operation.

During times of low solar energy gain and boosting of the water temperature is required, the electric booster heating unit will heat the water temperature to 60°C or up to 70°C depending upon the thermostat setting. If this water heater is installed with an in-series booster water heater, then this temperature can be 70°C or higher if the booster water heater is a continuous flow gas booster or 60°C or higher if the booster water heater is a storage water heater.

These temperatures are sufficiently hot to cause severe scalding. Water at this temperature may have been plumbed to fixtures where water hotter than 50°C is allowed, such as the kitchen and laundry.

Refer to:

- **"How Hot Should the Water Be?"** on page 10, and
 - **"Hotter Water increases the Risk of Scald Injury"** on page 11, and
 - **"Temperature Adjustment"** on page 13 (for an electric water heater), or **"Temperature Adjustment"** on page 16 (for a solar water heater), and
 - **"Solar Operation"** on page 14 (for a solar water heater).
- This water heater is only intended to be operated by persons who have the experience or the knowledge and the capabilities to do so.
 - This water heater is not intended to be operated by persons with reduced physical, sensory or mental capabilities i.e. the infirm, or by children. Children should be supervised to ensure they do not interfere with or play with or at the water heater.
 - Do not touch any exposed pipe work or fittings connecting the solar storage tank and the solar collectors, as this may result in a burn injury. Very high temperature hot water and in some circumstances high temperature steam can be generated by the solar collectors under certain conditions and this flows through the pipe work from the solar collectors to the solar storage tank.
Note: Any exposed pipe work or fittings in the collector circuit should be attended to and covered with insulation. Phone your nearest Solahart Dealer to arrange for an inspection.
 - If the electrical conduit to the water heater or the power supply cord or plug to the solar control unit is damaged, it must be replaced by a qualified person in order to avoid a hazard. The power supply cord and plug must be replaced with a genuine replacement part available from Solahart. Phone your nearest Solahart Dealer to arrange for an inspection.
 - The power lead from the solar controller must be plugged into a weatherproof electrical outlet if installed outdoors. Take care not to touch the power plug with wet hands.
 - This water heater uses 220 V - 240 V a.c. electrical power for the electrically operated components and operation of the control systems. The removal of the front covers or solar control unit cover will expose 220 V - 240 V a.c. wiring. They must only be removed by a qualified person. Do not operate the water heater with any of the covers removed.
 - This water heater is supplied with thermostats, over-temperature cut-outs, temperature sensors and a combination temperature pressure relief valve. These devices must not be tampered with or removed. The water heater must not be operated unless each of these devices is fitted and is in working order.

The Solahart warranty may not cover faults if relief valves or other safety devices are tampered with or if the installation is not in accordance with these instructions.

- **DANGER:** The operation of the over-temperature cut-out on a thermostat indicates a possibly dangerous situation. If the over-temperature cut-out operates, it must not be reset and the water heater must be serviced by a qualified person.
- Servicing of a water heater must only be carried out by qualified personnel. Phone your nearest Solahart Dealer.
- The lever on the temperature pressure relief valve and expansion control valve (if fitted) requires to be operated every six (6) months to clear any deposits and to ensure the valve and its drain line are not blocked.

Refer to:

- **“Relief Valves”** on page 8, and
- **“Minor Maintenance Every Six Months”** on page 20.
- In areas where there is a risk of freezing conditions, power must be available to the solar control unit at all times. The electrical supply to the solar control unit should not be switched off otherwise the freeze protection system will be rendered inoperable, and damage could result. If it is necessary to switch the power off to the solar control unit and there is a risk of freezing, then it is necessary to have a plumber drain the solar collectors and solar hot and solar cold pipes. Refer to **“Freeze Protection”** on page 19.
- For continued safety of this water heater, it must be installed, operated, and maintained in accordance with the Owner’s Guide and Installation Instructions.
- Only a person qualified to install or service a water heater can drain the water heater if this is required.
- Do not modify this water heater.

RELIEF VALVES

Temperature Pressure Relief Valve

This water heater incorporates a temperature pressure relief valve located near the top of the solar storage tank. This valve is essential for the water heater’s safe operation.

It is possible for the valve to discharge a quantity of water through the drain line during each heating period. This quantity should be equal to approximately 1/50 of the hot water used, as water expands by this volume when heated.

Expansion Control Valve

In many areas, including South Australia, Western Australia, and scaling water areas, it is mandatory an expansion control valve is fitted to the cold water line to the water heater.

The expansion control valve will discharge the quantity of water from its drain line during the heating period instead of the temperature pressure relief valve as it has a lower pressure rating.

Valve Operation

Continuous leakage of water from either valve and its drain line may indicate a problem with the water heater. Refer to **“Temperature Pressure Relief Valve or Expansion Control Valve Running”** on page 27.

⚠ Warning: Never block the outlet of either valve or their drain lines for any reason. A relief valve drain must be left open to atmosphere and be installed in a continuously downward direction.

In locations where water pipes are prone to freezing, the relief valve drain line must be insulated and not exceed 300 mm in length before discharging into a tundish through an air gap.

Operate the easing lever on the temperature pressure relief valve and expansion control valve once every six (6) months to clear any deposits and ensure the valve and its drain line are not blocked. **It is very important the lever is raised and lowered gently.** Refer to **“Minor Maintenance Every Six Months”** on page 20.

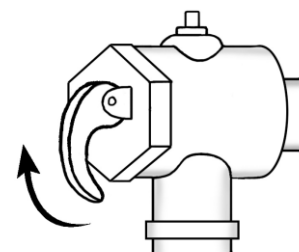
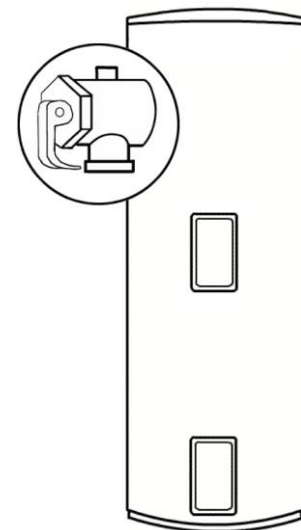

lift until water flows from the drain line – lower gently

outlet / drain line

⚠ Warning: Water discharged from the temperature pressure relief valve drain line will be hot. Exercise care to avoid any splashing of water by standing clear of the drain line's point of discharge when operating either valve's easing lever.

⚠ DANGER: Failure to operate the easing lever on the relief valve once every six (6) months may result in the solar storage tank cylinder failing, or under certain circumstances, exploding.

If water does not flow freely from the drain line when the lever is lifted, then the water heater must be checked. Phone your nearest Solahart Dealer to arrange for an inspection.

The temperature pressure relief valve should be replaced at intervals not exceeding five (5) years and the expansion control valve should be checked for performance or replaced at intervals not exceeding five (5) years. The checking of the valves performance or replacement should occur more frequently in areas where there is a high incidence of water deposits. Refer to **"Water Supplies"** on page 22.

INSTALLATION NOTES

This water heater must be installed:

- by a qualified person,
- in accordance with the installation instructions,
- in compliance with the Plumbing Code of Australia (PCA) and the Plumbing Standard AS/NZS 3500.4,
 - The solar storage tank is designed for either indoor or outdoor installation.
 - This water heater is intended to be permanently connected to the water mains and not connected by a hose-set. A braided flexible hose or semi-flexible connector may be used for connection to the water heater, where permitted by AS/NZS 3500.4.
- in compliance with the Australian / New Zealand Wiring Rules AS/NZS 3000,
 - An isolation switch must be installed at the switchboard in the electrical circuit to the water heater in accordance with the Wiring Rules, so the water heater can be switched off. Refer to **"Connections – Electrical"** on page 58.
 - The power supply wires are to be directly connected to the terminal block and earth tab connection, with no excess wire loops inside the front cover. The temperature rating of the power supply wires insulation must suit this application, or the wiring protected by insulating sleeving with an appropriate temperature rating if it can make contact with the internal storage cylinder. The temperature of the internal storage cylinder can reach 70°C to 75°C under normal operation and up to 75°C to 80°C could be reached during solar over-temperature operation.
- in compliance with all local codes and regulatory authority requirements.

Installation and commissioning requirements and details for the installing plumber and licensed electrical worker are contained on **pages 30 to 66**.

Mains pressure water supply

The water heater is designed to operate at mains pressure by connecting directly to the mains water supply.

The water heater is supplied with a temperature pressure relief valve with a pressure rating of 1000 kPa. If an expansion control valve has been installed on the cold water line to the water heater, this should have a pressure rating of 850 kPa.

The maximum mains water supply pressure for the water heater is 800 kPa if an expansion control valve is not installed, or 680 kPa if an expansion control valve is installed. If the mains supply pressure in your area exceeds these values, a pressure limiting valve must be installed.

A minimum water supply pressure of 200 kPa is required to enable the solar circulator and collector circuit system to operate effectively.

The supply pressure should be greater than 350 kPa for true mains pressure operation to be achieved.

ABOUT YOUR WATER HEATER

WATER HEATER APPLICATION

This water heater is designed for use in a single family domestic dwelling for the purpose of heating potable water. Its use in an application other than this may shorten its life.

MODEL TYPE

The water heater can be installed as:

- a standard electric water heater operating from the bottom heating unit only, or
- an enhanced frost protected open circuit solar water heater system (with associated solar control unit and solar collectors) with the top heating unit operating as the booster element and the bottom heating unit operating as part of an enhanced frost protection element.

The water heater tank is suitable for either indoor or outdoor installation. Water is stored in a vitreous enamel lined steel cylinder. Automatic safety controls are fitted to the water heater to provide safe and efficient operation.

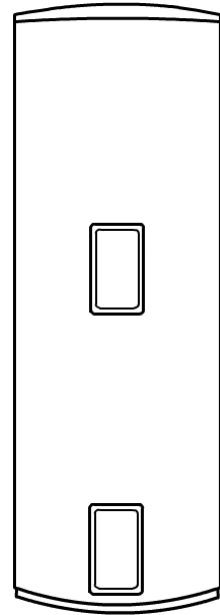

HOW HOT SHOULD THE WATER BE?

Electric Water Heater

The water heater features a tradesperson adjustable thermostat(s), which allows you to choose the most suitable temperature for your hot water needs. Refer to ["Temperature Adjustment"](#) on page 13.

To meet the requirements of the National Plumbing Standard the temperature of the stored water must not be below 60°C.

Solar Water Heater

When installed as a solar water heater, the solar collectors can heat the water to a temperature higher than the thermostat setting. The solar control unit will circulate water through the solar collectors until a temperature of 70°C to 75°C is reached during normal operation.

During periods of low solar energy gain, the water temperature can be boosted by the thermostatically controlled electric booster heating unit. Refer to ["Booster Control"](#) on page 17. Solahart recommends this tradesperson adjustable thermostat is set at 60°C to maximise solar contribution. Refer to ["Temperature Adjustment"](#) on page 16.

Note: AS 3498 requires that a water heater provides the means to inhibit the growth of Legionella bacteria in potable water. The solar water heater can satisfy this AS 3498 requirement provided the electric booster is energised for a sufficient period each day and the electric booster thermostat setting is 60°C or higher.

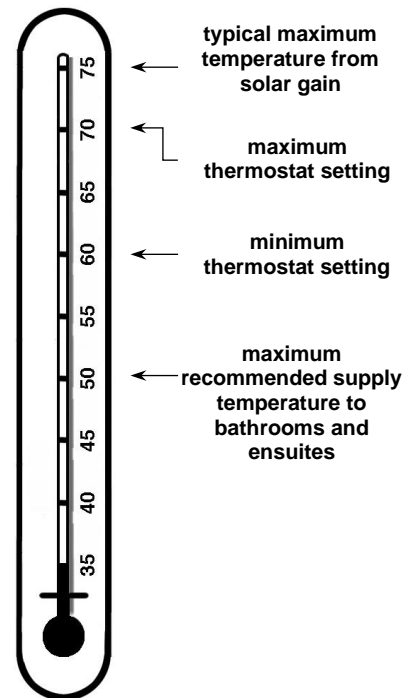

If the solar water heater is installed with an in-series continuous flow gas booster, then this requirement of AS 3498 can be satisfied provided the booster is energised, its preset outlet temperature setting is 70°C or higher and a remote temperature controller is not used.

If the solar water heater is installed with an in-series storage booster, then this requirement of AS 3498 can be satisfied provided the storage booster is energised and its thermostat setting is 60°C or higher.

HOTTER WATER INCREASES THE RISK OF SCALD INJURY

⚠ Warning: This water heater can deliver hot water at a temperature up to 70°C when installed as an electric water heater, and when installed as a solar water heater up to 75°C during normal operation and on occasion the water temperature may exceed 75°C. These temperatures are sufficiently hot to cause severe scalding. Water at this temperature may have been plumbed to fixtures where water hotter than 50°C is allowed, such as the kitchen and laundry.

Check the water temperature before use, such as when entering a shower or filling a bath or basin, to ensure it is suitable for the application and will not cause scald injury.

We recommend and it may also be required by regulations, that an approved temperature limiting device be fitted into the hot water pipe work to the bathroom and ensuite when this water heater is installed. This will keep the water temperature below 50°C at the bathroom and ensuite. The risk of scald injury will be reduced and still allow hotter water to the kitchen and laundry.

THERMOSTAT

A thermostat automatically controls the electricity supply to the heating unit so a constant temperature is maintained. The thermostat and its protective over temperature cut out is mounted inside the front cover of the water heater. Power is only used when heating is required. There is no need to switch the water heater off when it is not in use, except when you are on an extended holiday. The thermostat is fully automatic and power is only used when heating is required.

TO TURN OFF THE WATER HEATER

If you plan to be away from home for a few nights, we suggest you leave the water heater switched on.

If it is necessary to turn off the water heater:

- Switch off the electrical supply at the water heater isolating switch on the switchboard and at the isolating switch at the water heater (if installed).
- *Solar only* – Switch off the electrical supply to the solar control unit at the power outlet (refer to note below).
- Close the cold water isolation valve at the inlet to the water heater.

Notes – Solar Water Heater Installation

- The freeze protection system will be rendered inoperable if electrical power is not available at the solar control unit. Damage caused by freezing due to no power at the solar control unit is not covered by the Solahart warranty. Refer to **“Terms of the Solahart Warranty”** on page 4.
- If there is a risk of freezing, the electrical supply to the solar control unit should not be switched off unless the solar collectors and solar hot and solar cold pipes are drained, otherwise damage could result (refer to **“Freeze Protection”** on page 19).

TO TURN ON THE WATER HEATER

- Open the cold water isolation valve fully at the inlet to the water heater.
- *Solar only* – If the solar collectors and solar hot and solar cold pipes have been drained, it will be necessary to have the collector circuit purged of air. Phone your nearest Solahart Dealer.

If the electrical supply to the water heater has been switched off:

- *Solar only* – Switch on the electrical supply to the solar control unit at the power outlet. The power outlet must be switched on for the solar control unit to operate and solar gain to be achieved.
- Switch on the electrical supply at the water heater isolating switch on the switchboard and at the isolating switch at the water heater (if installed).
- Check and if required reset the timer, if one is installed.

PRECAUTIONS

Where damage to property can occur in the event of the water heater leaking, the water heater must be installed in a safe tray. Construction, installation and draining of a safe tray must comply with AS/NZS 3500.4 and all local codes and regulatory authority requirements.

The water heater must be maintained in accordance with the Owner's Guide and Installation Instructions. Refer to ["Maintenance Requirements"](#) on page 20 and to ["Anode Inspection and Replacement"](#) on page 23.

If this water heater is to be used where an uninterrupted hot water supply is necessary for your application or business you should ensure that you have back-up redundancy within the hot water system design. This should ensure the continuity of hot water supply in the event that this water heater were to become inoperable for any reason. We recommend you seek advice from your local Solahart Dealer or specifier about your needs and building back-up redundancy into your hot water supply system.

GOING ON HOLIDAYS

Electric or Solar Water Heater – If you plan to be away from home for one or two nights, we suggest you leave the water heater switched on. However, if you plan to stay away more than a few nights, conserve energy by switching off the electrical supply at the water heater isolating switch on the switchboard or at the isolating switch at the water heater (if installed).

Note: When the electrical supply is switched back on, the water heater will take some time to reheat the water. Depending upon the power supply connection to a standard electric or a solar water heater installation, hot water may not be available until the next day.

Solar Water Heater – the electrical supply at the power outlet to the solar control unit should not be switched off. The freeze protection system will be rendered inoperable if electrical power is not available at the solar control unit. Also if the system is not used for a period in excess of four (4) weeks it is recommended the solar collectors be covered.

Refer to ["To Turn Off The Water Heater"](#) on page 11.

VICTORIAN CUSTOMERS

Notice to Victorian Customers from the Victorian Building Authority. This water heater must be installed by a licensed person as required by the Victorian Building Act 1993.

Only a licensed person will give you a Compliance Certificate, showing that the work complies with all the relevant Standards. Only a licensed person will have insurance protecting their workmanship for 6 years. Make sure you use a licensed person to install this water heater and ask for your Compliance Certificate.

DOES THE WATER CHEMISTRY AFFECT THE WATER HEATER?

The water heater is suitable for most public water supplies, however some water chemistries may have detrimental effects on the water heater, and the solar collectors, components and fittings (if installed). Refer to ["Water Supplies"](#) on page 22. If you are in a known harsh water area or you are not sure of your water chemistry, have your water checked against the conditions [described on pages 22 to 24](#).

HOW LONG WILL THE WATER HEATER LAST?

The water heater is supported by a manufacturer's warranty ([refer to page 4](#)). There are a number of factors that will affect the length of service the water heater will provide. These include but are not limited to the water chemistry, the water pressure, the water temperature (inlet and outlet) and the water usage pattern. Refer to ["Precautions"](#) on page 12.

HOW YOUR ELECTRIC WATER HEATER WORKS

ELECTRIC WATER HEATER

Water is heated by the electric immersion heating unit. The thermostat controls the temperature. The power supply to the heating unit connects directly to the terminal block and earth terminal via the penetration on the underside of the lower front cover.

When the water heater is installed as a standard electric water heater, it will heat only with the bottom heating unit. Refer to "[Standard Electric Single Element Water Heater](#)" on page 13.

The water heater has caps covering brass plugs on either side of the tank. The plugs and caps block off the solar connection points and are not to be tampered with or removed.

STANDARD ELECTRIC SINGLE ELEMENT WATER HEATER

This type of installation will utilise only one heating unit with its own thermostat, located at the base of the water heater.

- **Continuous electricity supply**
This type of connection is suited to where the storage capacity is less than the normal daily usage.
- **Off-Peak electricity supply**
This type of connection will only allow heating to occur during set hours. A volume of water sufficient for the day's total use is heated and stored. This type of heating will be more economical due to reduced tariffs by the electricity authority.

TEMPERATURE ADJUSTMENT

The heating unit has its electricity supply controlled by a tradesperson adjustable thermostat. The thermostat requires a licensed electrical worker to make any temperature adjustments. The thermostat has a maximum temperature setting of 70°C and a minimum temperature setting of 60°C. The factory setting is 70°C for the thermostat at the bottom of the water heater.

We advise you to have a licensed electrical worker adjust the thermostat to the lowest setting which meets your needs, especially if there are young children or elderly people in the home. Refer to "[Hotter Water Increases the Risk of Scald Injury](#)" on page 11.

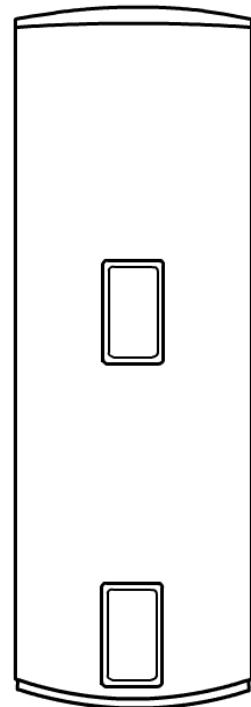

HOW YOUR SOLAR WATER HEATER WORKS

SOLAR WATER HEATER

The Solahart Streamline open circuit solar water heater system is designed for the solar collectors to be roof mounted and the vitreous enamel lined solar storage tank to be remotely installed at ground or floor level. The solar storage can be installed with Solahart L, LCS or CSA2007 solar collectors.

This water heater is designed to be installed as an electric boosted solar water heater with its booster heating unit connected to a power supply. The booster heating unit is housed under the upper front cover located at the midpoint of the tank. The power supply to the booster heating unit connects directly to the terminal block and earth terminal via the penetration on the underside of the upper front cover. This model also has an anti-freeze heating unit (frost element) housed under the lower front cover located toward the bottom of the tank.

The system has a level of freeze protection designed to guard the system against damage from freeze conditions (refer to “Freeze Protection” on page 19). The system must be installed with the full length of the solar hot and solar cold pipes insulated and power must be available at the solar control unit to offer protection against freeze damage (refer to “Warning: Plumber – Be Aware” on page 52). Freeze conditions occur below 6°C.

The system is not recommended for installation above 600 metres altitude. A system with a frost element has NO WARRANTY for freeze damage when installed above 600 metres altitude or if the solar hot and solar cold pipes are not insulated in accordance with the installation instructions or if power is not available at the solar control unit (refer to “Terms of the Solahart Warranty” on page 4).

Note: The Solahart warranty against freeze damage applies only to systems installed in Australia.

Although designed to be installed as an electric boosted solar water heater, the water heater may also be installed with an in-series continuous flow or storage booster.

If this water heater is installed with an in-series booster, then the electric booster heating unit will not be connected to a power supply and the references to the electric booster heating unit, thermostat and boosting controls in this Guide will not be applicable to the installation. For information relating to the function and operation of the in-series booster, refer to the Owners Guide and Installation Instructions supplied with the booster water heater.

SOLAR OPERATION

The operation of the circulator is controlled by the combination of:

- the hot sensor located at the outlet of the solar collectors.
The hot sensor measures the water temperature at the outlet of the solar collectors.
- the cold sensor located at the solar cold outlet at the base of the solar storage tank
The cold sensor measures the water temperature at the bottom of the solar storage tank.
- the differential controller located in the solar control unit.

Normal operation

As the sun heats the water in the solar collectors, the increase in temperature activates the circulator. The circulator switches on whenever the water in the solar collectors is hotter than the water in the solar storage tank. The circulator moves the cooler water from the solar storage tank to the solar collectors via the solar cold pipe, to be heated by the sun’s energy, and the hotter water from the solar collectors is circulated through the solar hot pipe to the solar storage tank.

This process continues whilst solar energy is available and the water in the solar storage tank requires heating. The circulator will deactivate when the water temperature in the solar storage tank is around 70°C to 75°C. The water heater will then enter Over-temperature operation.

During normal operation if the amount of solar energy available reduces, such as when the sky becomes very cloudy or the sun becomes lower in the sky in the late afternoon, and the water no longer gains useable heat from the solar collectors, the circulator will deactivate. The water heater will then enter standby mode.

Over-temperature operation

The purpose of the Over-temperature operation is to reduce the amount of overheating or 'stagnation' of water in the solar collectors. When the water in the solar storage tank has reached 70°C to 75°C and the circulator has deactivated, the solar collectors will continue to gain heat while solar energy is still available.

If the water in the solar collectors stagnates and its temperature becomes very high, the circulator will activate for a short period to transfer this extra energy to the solar storage tank. The circulator will deactivate when the water temperature in the solar collectors decreases. This process will either repeat for a maximum of eight cycles or until the water temperature in the solar storage tank reaches around 75°C to 80°C or the hot sensor does not sense another increase in water temperature to a stagnation level after a cycle is completed, i.e. the solar energy available reduces.

Night Time Cooling operation

The purpose of Night Time Cooling operation is to rid the solar storage tank of excess solar energy gained by Over-temperature operation during that day. The desired water temperature in the solar storage tank is to be between 60°C and 70°C.

If the solar control unit has entered Over-temperature operation during the day, then after the water temperature in the solar collectors reduces later in the day or early evening, the circulator will activate. Water from the solar storage tank will circulate through the solar collectors and excess heat in the water will radiate from the solar collectors reducing the temperature of the water. The water will circulate for a period of time and until the water temperature in the solar storage tank is around 60°C to 70°C. The water heater will then enter standby mode.

Freeze Protection operation

The purpose of Freeze Protection operation is to prevent freezing of water in the solar collectors and solar pipe work in very cold conditions. The water in the solar collectors will cool during periods of no solar gain. In very cold conditions, such as overnight and very early in the morning before sunrise, the water temperature can approach freezing point.

If the hot sensor measures that the water temperature in the solar collectors is approaching freezing, the circulator will activate. Water from the solar storage tank, containing more energy than the water in the solar collectors, will circulate through the solar collectors keeping the water temperature above freezing point. The circulator will remain on for some minutes and until the hot sensor measures a water temperature at a safe level above freezing. When both of these conditions are met, the circulator will deactivate. The water heater will then enter standby mode.

This process will repeat whenever the hot sensor measures that the water temperature in the solar collectors is approaching freezing.

The anti-freeze heating unit will turn on when the circulator activates and the cold sensor measures a very low water temperature at the bottom of the solar storage tank. The purpose of the anti-freeze heating unit is to provide additional energy to the water to assist in the prevention of freezing in the solar pipe work and solar collectors. The anti-freeze heating unit will turn off when either the water temperature has risen by a few degrees or the circulator deactivates. The water heater will then enter standby mode.

Refer to "[Freeze Protection](#)" on page 19 and "[Warning: Plumber – Be Aware](#)" on page 52.

Standby mode

The water heater will be in Standby mode whenever conditions are not favourable for solar heating in Normal operation, and Over-temperature operation and Night Time Cooling are not required or have been completed, and conditions are not cold enough for or in-between Freeze Protection operation.

Solar Monitor LED operation

The LEDs on the Solar Monitor, located on the side of the solar control unit, operate to show the operational mode of the water heater. Refer also to “Solar Monitor” on page 18.

Mode	Green LED		Red LED
	power on* > 48 hours	power on* < 48 hours	
Normal operation	rapid pulse	3 flashes	off **
Over-temperature operation	rapid pulse	3 flashes	off, or solid then off
Night Time Cooling operation	rapid pulse	3 flashes	off
Freeze Protection operation	rapid pulse	3 flashes	off
Standby mode	solid	slow pulse	off

Notes

* Power from the GPO to the solar control unit.

** In Normal Operation the red LED may emit a rapid pulse for a short period of time under certain circumstances (refer to “Rapid Pulsing” on page 28).

ELECTRIC BOOSTING

Water stored in the solar storage tank can be heated by an electric booster heating unit. The booster heating unit is for heating the water at times of low solar energy gain, such as during very cloudy or rainy weather, or during the colder months.

The amount of water heated by the raised booster heating unit of the Streamline solar storage tank is 170 litres (320 model) or 140 litres (270 model).

The water heater is most suited for the booster heating unit to be connected to either a continuous, or a time of use, or an extended Off-Peak (overnight and day) electricity supply. A timer can also be used to control the boosting periods and help maximise solar savings. Refer to “Booster Control” on page 17.

The booster heating unit may be connected to an Off-Peak (overnight) electricity supply, however this will only allow the booster to heat the water overnight. If this type of connection is considered, care must be taken to ensure there is sufficient boost capacity to meet the household’s full day and night’s hot water supply during periods of no or low solar gain, particularly in cold weather.

The booster heating unit is controlled by an electric thermostat. The thermostat and its over-temperature energy cut-out are mounted on the solar storage tank behind the upper front cover. If required, the water is heated automatically to the thermostat setting by the booster heating unit when power is available.

TEMPERATURE ADJUSTMENT

The water heater features a tradesperson adjustable thermostat that automatically controls the electricity supply to the booster heating unit located at the mid-point of the water heater. This requires a licensed electrical worker to make any temperature adjustments. The thermostat is factory set at 60°C. The thermostat has a maximum temperature setting of 70°C and a minimum temperature setting of 60°C.

Solahart recommends the thermostat is set at 60°C to maximise solar contribution.

We advise you to have a licensed electrical worker adjust the thermostat to the lowest setting which meets your needs, especially if there are young children or elderly people in the home. Refer to “Hotter Water Increases the Risk of Scald Injury” on page 11.

Refer to “Booster Control” on page 17.

The operation of the anti-freeze heating unit (frost element) is not controlled by its thermostat. The thermostat acts as a backup safety device to control the electricity supply to the heating unit. This thermostat does not require to be adjusted.

BOOSTER CONTROL

An isolating switch is installed in the electrical meter box for the solar storage tank, and a second isolating switch may be installed adjacent to the solar storage tank. These should be left switched on to allow the booster heating unit to operate if required. The booster heating unit is for heating the water at times of low solar energy gain, such as during very cloudy or rainy weather, or during the colder months.

Leaving the isolating switch(s) switched on will also provide a sufficient period of time each day for the booster heating unit to operate, if required, to satisfy the requirements of AS 3498.

The booster heating unit will only activate if heating is required and power is available from the switchboard. When the water is below the thermostat setting, the booster heating unit will turn on and heat the water. The booster heating unit will automatically turn off when the temperature of the water reaches the thermostat setting.

Timer Control Switch

A suitably rated timer control switch can be installed and will help maximise energy savings with an electrically boosted solar water heater connected to a **continuous, time of use or extended Off-Peak (overnight and day)** electricity supply. Further information for a licenced electrical worker on the recommended methods of wiring the timer are outlined in **“Booster Control”** on page 61.

Programming the Timer

Power must be available to the timer control switch before the booster heating unit can be activated.

The timer control switch should be programmed:

- to suit the hot water consumption pattern of the household,
- with the end of the period to coincide with the commencement of the evening hot water usage,
A second period, such as prior to the morning hot water usage, may be necessary.
- to enable a boosting period of not less than the recommended continuous length of time for boosting,
- for a period when power will be available to the timer.

Note: When daylight saving time applies, you may consider resetting the timer accordingly.

The recommended continuous length of time for boosting is:

Model	Minimum winter cold water temperature		Temperature rise	Booster heating unit size		
				2.4 kW	3.6 kW	4.8 kW
270	Cool / temperate climate	10°C	50°C	3 ½ hours	2 ½ hours	1 ¾ hours
	Temperate / sub-tropical climate	15°C	45°C	3 ¼ hours	2 ¼ hours	1 ¾ hours
	Tropical climate	20°C	40°C	2 ¾ hours	2 hours	1 ½ hours
320	Cool / temperate climate	10°C	50°C	4 ¼ hours	3 hours	2 ¼ hours
	Temperate / sub-tropical climate	15°C	45°C	3 ¾ hours	2 ½ hours	2 hours
	Tropical climate	20°C	40°C	3 ½ hours	2 ¼ hours	1 ¾ hours

Factory fitted booster heating unit size is 3.6 kW

The recommended boosting periods are sufficient to allow the booster heating unit to heat up the boost volume of the solar storage tank to 60°C where the winter cold water temperatures do not fall below those shown. This may be necessary during periods of no or very low solar energy gain through the solar collectors, such as during constant rain or extremely cloudy weather, particularly in winter when the incoming cold water temperature is lower. The period will also provide a sufficient heat up time for the electric booster to operate, if required, to satisfy the requirements of AS 3498.

The booster heating unit will only activate if heating is required and power is available from the timer. When the water is below the thermostat setting, the booster heating unit will turn on and heat the water. The booster heating unit will automatically turn off either when the temperature of the water reaches the thermostat setting or at the end of the timer period, whichever comes first.

SOLAR MONITOR

A solar monitor is located on the side of the solar control unit and houses a green and a red LED.

The green LED, marked “Solar”, indicates the current operational mode of the solar water heater and the red LED, marked “Attention”, may indicate a potential fault mode.

The green LED will emit either a constant glow, a constant pulsing or a series of flashes, with a two (2) second interval between each series.

The red LED will emit either a constant glow, a constant pulsing or a series of flashes with a two (2) second interval between each series. A constant glow or pulsing does not necessarily mean there is a fault with the system. A series of flashes indicates there may be a particular fault condition with the system.

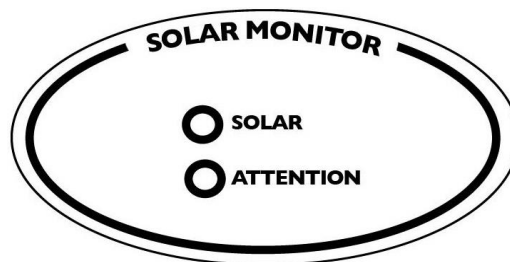

The operational modes are:

Flashes	Operational Modes
solid green (remains on)	Standby mode
green slow pulse	Standby mode (power on for less than 48 hours)
green rapid pulse	Circulating water through collectors
3 x green	Circulating water through collectors (power on for less than 48 hours)
no green (remains off)	Power outage or call for service

Flashes	Indicator or Fault Modes
solid red (remains on)	Hot sensor temperature greater than 130°C
red rapid pulse	Temperature rise across collector greater than 45°C (circulator at full speed)
3 x red	Hot sensor in collector – short circuit
4 x red	Hot sensor in collector – open circuit
5 x red	Cold sensor –short circuit
6 x red	Cold sensor – open circuit

If the power supply to the solar control unit is on and the green LED is off or the red LED is flashing, this indicates there may be a fault with the water heater. The red LED may emit from three (3) to six (6) flashes in each series of flashes. A constant glow or pulsing of the red LED does not necessarily mean there is a fault with the system.

Notes

- If the system is in standby mode with the green LED emitting either a constant glow or slow pulsing flashes (circulator is off) and the solar storage tank is full of hot water, the red LED may simultaneously emit a constant glow if solar radiation is still being received by the solar collectors. This does not indicate a fault. The red LED will go out when the temperature in the solar collectors decreases.
- During periods of high solar radiation and the circulator activates after having been off (the green LED will emit either a rapid pulse or a series of three flashes), it is possible the red LED may simultaneously emit a rapid pulse for a period of up to ten (10) minutes. This does not indicate a fault.

If the red LED continues to emit a rapid pulse for longer than ten (10) minutes, or emits a series of flashes, then count the number of flashes and phone your nearest Solahart Dealer to arrange for an inspection.

FREEZE PROTECTION

The system has a level of freeze protection designed to guard the system against damage from freeze conditions. The system must be installed with the full length of the solar hot and solar cold pipes insulated and power must be available at the solar control unit to offer protection against freeze damage (refer to **“Warning: Plumber – Be Aware”** on page 52). Freeze conditions occur below 6°C.

Note: The Solahart warranty against freeze damage applies only to systems installed in Australia.

The anti-freeze control is designed to recirculate a small amount of water from the solar storage tank through the solar pipe work and solar collectors during periods of low temperatures. This is to prevent the water inside the pipe work and collectors from freezing.

Frost Element Model

Additional freeze protection is provided by the anti-freeze heating unit on a frost element model tank. The anti-freeze heating unit is for heating the water at the bottom of the solar storage tank at times of low cold water temperature. The anti-freeze heating unit provides additional energy to the water to assist in the prevention of freezing in the solar pipe work and solar collectors.

The anti-freeze heating unit is supplied with power from and controlled by the solar controller and will only be energised when the water temperature is very low and the circulator activates in the Freeze Protection operation mode. The water temperature is monitored by the cold sensor. The anti-freeze heating unit will be de-energised when either the frost mode is shut down or the water temperature has risen by a few degrees.

It is essential the electrical circuit to the solar control unit is continually turned on if there is a risk of freezing, for the anti-freeze heating unit to operate and offer additional freeze protection. The Solahart warranty does not cover damage caused by freeze conditions when the electrical circuit to the solar control unit is turned off or interrupted.

A system with a frost element has NO WARRANTY for freeze damage when installed above 600 metres altitude or if the solar hot and solar cold pipes are not insulated in accordance with the installation instructions or if power is not available at the solar control unit (refer to **“Terms of the Solahart Warranty”** on page 4).

Notes

- A system with a frost element is not covered for freeze damage above 600 metres altitude by the Solahart warranty.
- The freeze protection system will be rendered inoperable if electrical power is not available at the solar control unit. Damage caused by freezing due to no power at the solar control unit, is not covered by the Solahart warranty.
- If it is necessary to switch the power off to the solar control unit and there is a risk of freezing, then it is necessary to have a plumber drain the solar collectors and solar hot and solar cold pipes.
- Refer to **“Terms of the Solahart Warranty”** on page 4.

MAINTENANCE REQUIREMENTS

MINOR MAINTENANCE EVERY SIX MONTHS

It is recommended minor maintenance be performed every six (6) months. Minor maintenance can be performed by the dwelling occupant.

The minor maintenance includes:

- Operate the easing lever on the temperature pressure relief valve. **It is very important the lever is raised and lowered gently.** Refer to “**Relief Valves**” on page 8.

⚠ Warning: Water discharged from the temperature pressure relief valve drain line will be hot. Exercise care to avoid any splashing of water by standing clear of the drain line's point of discharge when operating the valve's easing lever.

- Operate the easing lever on the expansion control valve (if fitted). **It is very important the lever is raised and lowered gently.** Refer to “**Relief Valves**” on page 8.
- Check the drain line from the safe tray (if one is installed) is not blocked.
- Solar Water Heater – Check the status of the LEDs. The green LED should be illuminated (either solid, pulsing or flashing). The red LED should be off. Refer to “**Solar Monitor**” on page 18 and “**Household Maintenance Around the Solar Storage Tank**” on page 21.

It is important to ensure the solar controller and circulator are operating correctly, particularly at the onset of the colder winter season. Solar gain will not be achieved and the freeze protection system will be rendered inoperative if the solar controller or circulator are not operating.

MAJOR SERVICE EVERY FIVE YEARS

It is recommended a major service be conducted on the water heater every five (5) years. If an anode replacement is conducted sooner than a major service, then the major service should coincide with the replacement.

⚠ Warning: Servicing of a water heater must only be carried out by a qualified person. Phone your nearest Solahart Dealer.

Note: The five year service and routine replacement of any components, such as the anode and relief valve(s), are not included in the Solahart warranty. A charge will be made for this work. Only genuine replacement parts should be used on this water heater.

The major service includes the following actions:

- Replace the temperature pressure relief valve.
- Inspect and flush the expansion control valve (if fitted). If required, replace the valve.
- Inspect and if required, replace the anode.
If the anode is not replaced, it should be replaced within five (5) years of this service (refer to “**Anode Inspection and Replacement**” on page 23).
- Check the electric heating unit(s) for excessive calcium build up or corrosion and replace if necessary.
- Visually check the unit for any potential problems.
- Inspect all connections.
- Check the drain line from the safe tray (if one is installed) is not blocked.
- *Solar only* – Check the solar control unit for correct operation.
- *Solar only* – Flush and bleed the solar collectors.
- *Solar only* – Clean the collector glass.
- *Solar only* – Check the insulation on the solar hot and solar cold pipes. If required, insulate exposed pipe work and repair or replace degraded insulation.

Note: The water heater may need to be drained during this service. After the completion of the service, the water heater will take some time to reheat the water. Depending upon the power supply connection to the heating unit, hot water may not be available until the next morning.

HOUSEHOLD MAINTENANCE AROUND THE SOLAR STORAGE TANK

Care should be taken when conducting general household maintenance, such as lawn mowing and grass cutting, around the solar storage tank. Careless use of devices such as a whipper snipper could damage or cut a sensor lead or the electrical conduit or electrical cables.

If a sensor lead or the electrical conduit or an electrical cable is damaged or cut, solar contribution may not be achieved and the freeze protection system may be rendered inoperative. In addition, if the electrical conduit or an electrical cable has been damaged or cut, wiring may be exposed leading to a dangerous situation.

On a regular basis, inspect around the water heater for insect infestations, such as ants. Insects may look for a warm place to nest, particularly in wet weather. Insects encroaching into or nesting in the water heater and the solar control unit can interfere with the operation of the water heater and also damage components. Spray insecticide around the base of the water heater if necessary to rid the area of insects.

COLLECTOR GLASS

Ensure the glass on your solar collectors is free of dust, salt spray or any other matter which may reduce the effectiveness of the solar collectors. Rainfall should keep the collector adequately clean. It is recommended the collector glass be washed clean at least every three months should adequate rain not have fallen in this period.

Collector glass can be hosed down or if the solar collectors are accessible such as on a trafficable roof, wash the collector glass with water and a soft brush when the solar collectors are cool, such as early in the morning. In extremely dusty areas extra attention may need to be given to keeping the collector glass clean.

Have any trees trimmed which may shade the solar collectors.

Stone Guards are available to provide a level of protection to the collectors against vandalism or accidental damage. Refer to your local Solahart Dealer for details.

Solahart solar collectors have passed the AS/NZS 2712 requirements for resistance to hailstone damage, so it is not normally necessary to fit a guard to a collector.

WATER SUPPLIES

This water heater must be installed in accordance with this advice to be covered by the Solahart warranty.

This water heater is manufactured to suit the water conditions of most public reticulated water supplies. However, there are some known water chemistries which can have detrimental effects on the water heater and its operation and / or life expectancy. If you are unsure of your water chemistry, you may be able to obtain information from your local water supply authority. This water heater should only be connected to a water supply which complies with these guidelines for the Solahart warranty to apply.

CHANGE OF WATER SUPPLY

The changing or alternating from one water supply to another can have a detrimental effect on the operation and / or life expectation of a water heater cylinder, a temperature pressure relief valve, a heating unit and a solar collector in an open circuit solar water heater system.

Where there is a changeover from one water supply to another, e.g., a rainwater tank supply, bore water supply, desalinated water supply, public reticulated water supply or water brought in from another supply, then water chemistry information should be sought from the supplier or it should be tested to ensure the water supply meets the requirements given in these guidelines for the Solahart warranty to apply.

ANODE

The vitreous enamel lined cylinder of the water heater is only covered by the Solahart warranty when the total dissolved solids (TDS) content in the water is less than 2500 mg/L and when the correct colour coded anode is used. If an incorrect colour coded anode is used in the water heater, any resultant faults will not be covered by the Solahart warranty. In addition, the use of an incorrect colour coded anode may shorten the life of the water heater cylinder.

The correct colour coded anode must be selected and fitted to the water heater in accordance with the following advice and the **Anode Selection chart** on page 22 for the Solahart warranty to apply to the water heater cylinder.

Total Dissolved Solids	Anode colour code
0 – 40 mg/L	Green
40 – 150 mg/L	Green or Black
150 – 400 mg/L	Black
400 – 600 mg/L	Black or Blue
600 – 2500 mg/L	Blue
2500 mg/L +	Blue (no cylinder warranty)

The changing of an anode must be carried out by a qualified person.

Note: Some water analysis reports may state the conductivity of the water rather than the level of total dissolved solids. Conductivity, measured in microsiemens per centimetre ($\mu\text{S} / \text{cm}$), is directly proportional to the TDS content of the water. TDS, in mg / L, is approximately 70% of the conductivity in $\mu\text{S} / \text{cm}$.

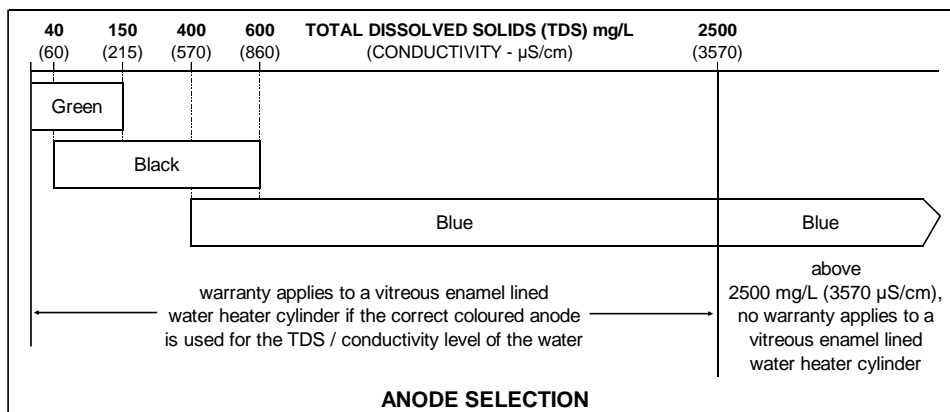

ANODE INSPECTION AND REPLACEMENT

The anode installed in this water heater will slowly dissipate whilst protecting the cylinder. The life of the cylinder may be extended by replacing the anode.

For water supplies which are either softened or desalinated, or where the water supply may alternate between a water tank and a reticulated public supply or another supply, or where there is a variable supply (e.g. from a bore or public reticulated supply from various water sources), the anode must be inspected (and replaced if there is any sign of depletion) within five (5) years of installation, and within every five (5) years thereafter.

For all water supplies, if the anode is not replaced during a major service (refer to “**Major Service Every Five Years**” on page 20) then the maximum time after its installation when the anode should be replaced for this water heater is ten (10) years.

CAUTION

If the water supply has a TDS greater than 150 mg/L and a green anode has not been changed to a black anode, or if the TDS is greater than 600 mg/L and the anode has not been changed to a blue anode, there is the possibility the anode may become overactive and hydrogen gas could accumulate in the top of the water heater during long periods of no use.

If, under these conditions, the water heater has not been used for two or more weeks the following procedure should be carried out before using any electrical appliances (automatic washing machines and dishwashers) which are connected to the hot water supply.

The hydrogen, which is highly flammable, should be vented safely by opening a hot tap and allowing the water to flow. There should be no smoking or naked flame near the tap whilst it is turned on. Any hydrogen gas will be dissipated. This is indicated by an unusual spurting of the water from the tap. Once the water runs freely, any hydrogen in the system will have been released.

SATURATION INDEX

The saturation index is used as a measure of the water's corrosive or scaling properties. The saturation index figures stated are calculated using a water temperature of 80°C.

In a corrosive water supply, the water can attack copper parts and cause them to fail.

Where the saturation index is less than -1.0 , the water is very corrosive and the Solahart warranty does not apply to a copper sheathed heating unit or a solar collector in an open circuit solar water heater system. A corrosion resistant heating unit must be used for the Solahart warranty to apply to the heating unit.

In a scaling water supply calcium carbonate is deposited out of the water onto any hot metallic surface.

Where the saturation index exceeds $+0.40$, the water is very scaling. An expansion control valve must be fitted on the cold water line after the non-return valve to protect and for the Solahart warranty to apply to the temperature pressure relief valve and water heater cylinder. Solar collectors in an open circuit solar water heater system should be covered when the water heater is not intended to be used for more than four (4) weeks.

Where the saturation index exceeds $+0.80$, the Solahart warranty does not apply to a standard watts density heating unit or a solar collector in an open circuit solar water heater system. The bottom triple blade heating unit fitted as standard to this water heater is a low watts density type. The top heating unit, which is the booster heating unit for a solar water heater, must be of a low watts density type for the Solahart warranty to apply to the heating unit.

Water which is scaling may be treated with a water softening device to reduce the saturation index of the water.

Refer to the **Saturation Index chart** on page 24.

Contact your nearest Solahart Dealer if a replacement heating unit is required.

Refer to the **cold water connection detail on page 54** for the position of the expansion control valve.

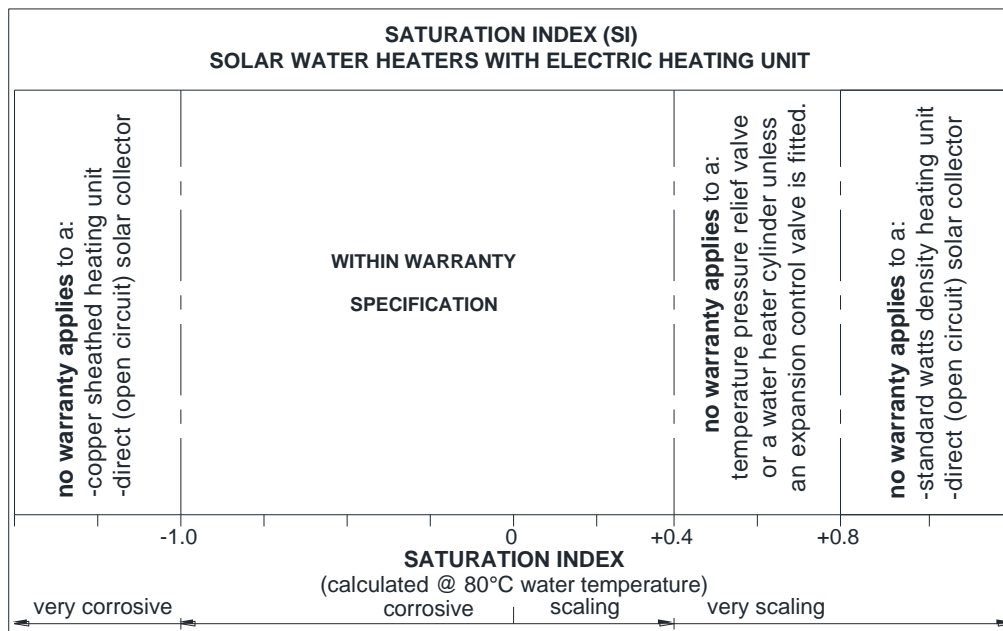
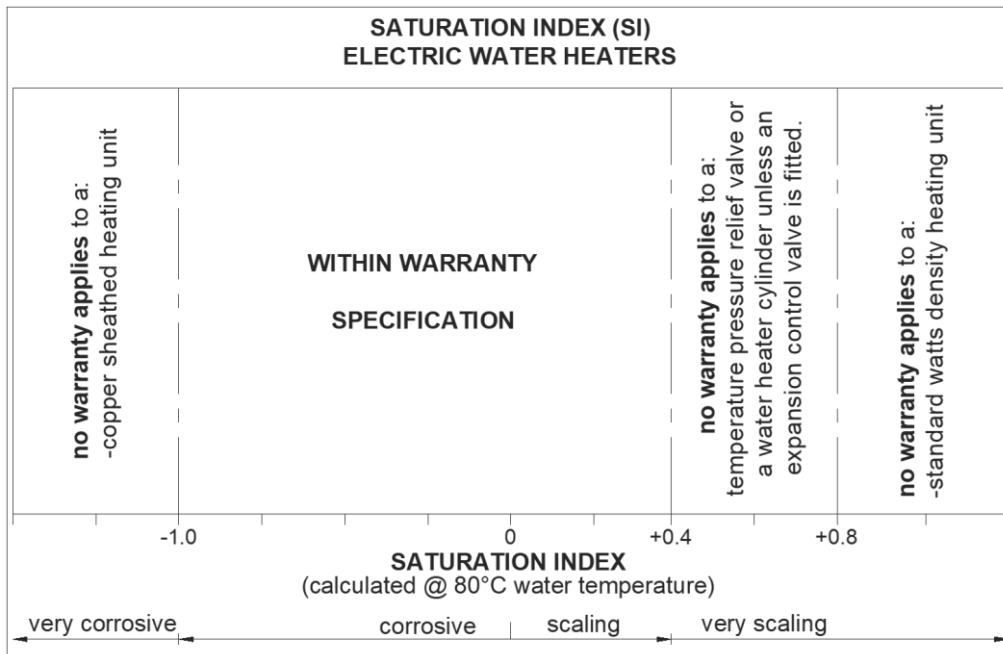

SUMMARY OF WATER CHEMISTRY ADVICE AFFECTING WARRANTY

The water heater, solar collectors and their components are not suitable for certain water chemistries. Those chemistries are listed below. If the water heater is connected at any time to a water supply with the following water chemistry, the Solahart warranty will not cover any resultant faults on the components listed below:

Water Chemistry

- Total Dissolved Solids (TDS) > 2500 mg/L
- Total Dissolved Solids (TDS) not suitable for anode type
- Saturation Index (SI) < -1.0
- Saturation Index (SI) > +0.4 (if an expansion control valve is not fitted)
- Saturation Index (SI) > +0.8

Component

- water heater cylinder
- water heater cylinder
- solar collector
- copper sheathed heating unit
- water heater cylinder
- temperature pressure relief valve
- solar collector
- standard watts density heating unit

SAVE A SERVICE CALL

Check the items below before making a service call. You will be charged for attending to any condition or fault that is not related to manufacture or failure of a part.

NOT ENOUGH HOT WATER (OR NO HOT WATER)

This can occur with new installations and is normally related to some misunderstandings as to the use of the booster heating unit.

- **Is the electricity switched on?**

Inspect the isolating switch marked "HOT WATER" or "WATER HEATER" at the switchboard and the isolating switch (if one is installed) near the water heater and ensure they are turned on.

Note: Check the electricity supply to which the water heater is connected. If on an Off-Peak or time controlled electricity supply, remember heating hours are restricted.

Check the fuse or circuit breaker marked "HOT WATER" or "WATER HEATER" at the switchboard.

- **Are you using more hot water than you think?**

Is one outlet (especially the shower) using more hot water than you think?

Very often it is not realised the amount of hot water used, particularly when showering. Carefully review the family's hot water usage. As you have installed an energy saving appliance, energy saving should also be practised in the home. Adjust your water usage pattern to take advantage of maximum solar gains.

Have a plumber install a flow control valve to each shower outlet to reduce water usage.



- **Thermostat setting**

Ensure the thermostat setting is appropriate. You may choose to have a licensed electrical worker adjust the thermostat upwards to gain additional hot water capacity when boosting. Refer to "[Temperature Adjustment](#)" on page 13 (for an electric water heater) or "[Temperature Adjustment](#)" on page 16 (for a solar water heater).

Warning: Hotter water increases the risk of scald injury.

- **Relief valve running**

Is the relief valve discharging too much water?

Refer to "[Temperature Pressure Relief Valve or Expansion Control Valve Running](#)" on page 27.

- **Insufficient sunlight for solar**

Insufficient sunlight due to cloudy weather during hotter months or low solar energy contribution in colder months may mean the booster heating unit is required to boost more often.

Ensure the booster heating unit is being used as advised. Refer to "[Booster Control](#)" on page 17.

- **Solar booster heating unit not operating**

Refer to "[Is the electricity turned on?](#)" on page 25.

Check the timer (if one is installed) and its settings to ensure power is available to the booster heating unit.

Note: Check the electricity supply to which the unit is connected. If on an Off-Peak or time controlled supply, remember heating hours are restricted.

- **Solar Control Unit**

Check the power outlet for the solar control unit is switched on.

- **Green LED is off or red LED is flashing on Solar Monitor**

If the green LED is off or the red LED is flashing on the Solar Monitor label, there may be a problem with the solar water heater operation and solar gain is not being achieved. This will result in the booster heating unit operating to provide all of the hot water required.

Switch off the electrical supply at the power outlet to the solar control unit for a few seconds, then switch on again.

If the green LED remains off or the red LED recommences to flash, then count the number of flashes and phone your nearest Solahart Dealer to arrange for an inspection.

- **Collectors shaded**

If trees or other objects shade the solar collectors or if the glass is dirty, the effectiveness of the solar collectors will be greatly reduced. Have the trees trimmed or the solar collectors relocated if the obstruction is permanent or clean the collector glass (refer to **“Collector Glass”** on page 21).

- **Collector area is too small**

For most installations, the number of solar collectors recommended in Solahart literature has been proven to provide the required solar energy to meet the average family needs. However, in some circumstances, it may be necessary to install an additional solar collector.

- **Air in collectors (no solar gain)**

It is possible under certain conditions, such as when the pipe work has been opened, that air may become trapped in the solar collectors. This will prevent the circulator from moving water around the collector circuit. Have the collector circuit purged of air. Phone your nearest Solahart Dealer.

WATER NOT HOT ENOUGH – SOLAR

You may find that due to heavy hot water usage or low solar energy gain the water temperature may be lower than normally expected. Ensure the booster is being used as advised. If a timer is installed, you will need to carefully plan your use of the booster heating unit to boost the water temperature on such occasions.

A lower water temperature may be noticed in the morning when the booster heating unit has not been energised overnight. This in particular may be experienced during periods of low solar energy gain, or if there has been heavy hot water usage the previous night.

If higher temperature water is required, particularly in the morning, then use of the booster heating unit is necessary to raise the temperature of the water in the top section of the cylinder.

If the water heater is connected to an Off-Peak (overnight) electricity supply, then switching to an Extended Off-Peak (overnight and day) supply should be considered. If a timer is being utilised, then a timed boost period in the afternoon prior to the evening usage should be considered.

Refer to **“Booster Control”** on page 17.

NOISE FROM THE SOLAR COLLECTORS

During periods of higher solar radiation or lower hot water usage and the solar storage tank is full of hot water, the water heater may undergo Over-temperature operation (refer to **“Over-temperature operation”** on page 15). If this mode of operation has occurred and the circulator has deactivated, the water in the solar collectors will continue to gain heat and increase in pressure when solar radiation is still available. This increase in heat and pressure is greater when higher performing selective surface solar collectors are installed compared to non-selective surface collectors.

When a hot tap is opened, this pressure is released and the high temperature water may turn to steam creating a sudden and loud rumbling noise and even a rattling or banging noise of the solar collectors against the roof cladding material. This results from the higher level of solar radiation and the water in the solar storage tank being at its maximum temperature and is not caused by a fault with the solar water heater.

TEMPERATURE PRESSURE RELIEF VALVE OR EXPANSION CONTROL VALVE RUNNING

- **Normal Operation**

It is normal and desirable the temperature pressure relief valve or expansion control valve (if fitted) allows a quantity of water to escape during the heating cycle. This quantity should be equal to approximately 1/50 of the hot water used, as water expands by this volume when heated. However, if it discharges more than a bucket full of water in 24 hours, there may be another problem.

The expansion control valve (if fitted) will discharge water instead of the temperature pressure relief valve as it has a lower pressure rating. A benefit is that energy is conserved as the discharged water is cooler. This valve is installed in the cold water line to the water heater (refer to the **cold water connection diagram** on page 54).

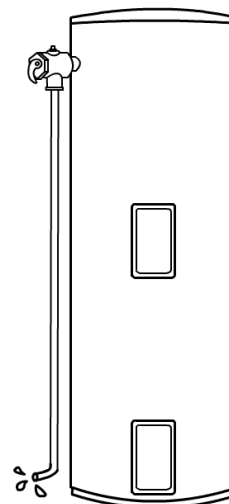

- **Continuous dribble**

Try gently raising the easing lever on the relief valve for a few seconds (refer to **“Relief Valves”** on page 8). This may dislodge a small particle of foreign matter and clear the fault. Release the lever gently.

- **Steady flows for long period (often at night)**

This may indicate the mains water pressure sometimes rises above the designed pressure of the water heater. Ask your installing plumber to fit a pressure limiting valve.

⚠ Warning: Never replace the relief valve with one of a higher pressure rating.

- **Heavy flows of hot water from the temperature pressure relief valve until water heater is cold - then stops until water reheats**

The water heater **must** be switched off at the isolating switch or switchboard. Phone your nearest Solahart Dealer to arrange for an inspection.

HIGHER THAN EXPECTED ELECTRICITY BILLS

Should you at any time, feel your electricity bill is higher than expected, we suggest you check the following points. With a solar hot water system, maximum electrical energy savings can be achieved with careful planning of hot water usage.

- Is the relief valve running excessively?

Refer to **“Temperature Pressure Relief Valve or Expansion Control Valve Running”** on page 27.

- Is one outlet (especially the shower) using more hot water than you think?

Refer to **“Not Enough Hot Water”** on page 25.

- Is there a leaking hot water pipe, dripping hot water tap, etc?

Even a small leak will waste a surprising quantity of hot water and energy. Replace faulty tap washers, and have a plumber rectify any leaking pipe work.

- Has there been an increase in hot water usage?

An increase in hot water usage may result in an increase in booster operation.

- Are you using the booster heating unit on the solar water heater properly?

Refer to **“Booster Control”** on page 17.

- Has your water heating tariff rate been increased by your electricity retailer since your previous bill?

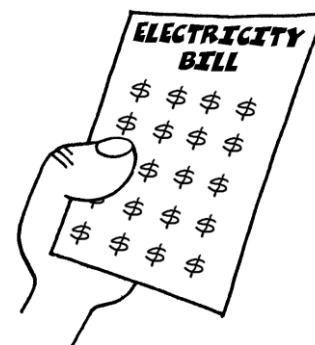

ELECTRICITY SUPPLY AND TARIFF

The electricity tariff to which your water heater is connected will determine the overall operating cost of the system. It is important you are aware of this tariff.

A standard electric water heater installation may be connected to a Domestic / Continuous or Time of Use, Extended Off-Peak (overnight and day) or extended time controlled, or Off-Peak (overnight) or time controlled supply. An Off-Peak (overnight) or time controlled supply will only allow heating to occur during set hours. This type of heating will be more economical due to reduced tariffs by the electricity authority.

A solar water heater installation may have the booster heating unit connected to a Domestic / Continuous or Time of Use, Extended Off-Peak (overnight and day) or extended time controlled, or Off-Peak (overnight) or time controlled supply. The hours of availability for the electrical supply and the tariff to which your solar water heater is connected will play an important role in the overall effectiveness of the system. An Off-Peak (overnight) or time controlled supply will only allow the booster to heat the water overnight. It is important you are aware of the hours of electricity supply to enable you to take full advantage of the boosting period.

GREEN LED IS NOT ILLUMINATED ON SOLAR MONITOR

Check the power outlet for the solar control unit is switched on.

If the power outlet for the solar control unit is switched on, switch off for a few seconds and then switch on again. If the green LED remains off there may be a fault with the water heater. Phone your nearest Solahart Dealer to arrange for an inspection.

RED LED ILLUMINATED ON SOLAR MONITOR

The illumination of the red LED does not necessarily mean there is a fault with the system. A constant glow or rapid pulsing of the red LED indicates an operational mode of the water heater.

Constant Glow

When the water heater has entered Over-temperature operation, the water in the solar collectors will continue to gain heat whilst solar energy is still available. The red LED will commence to emit a constant glow when sufficient solar energy has been received to activate the circulator. This indicates a build-up in temperature of the water in the solar collectors and does not represent a fault. The red LED will stop glowing when the circulator has moved the excess energy from the solar collectors to the solar storage tank.

When eight Over-temperature cycles have been completed and if solar energy is still available, the red LED will emit a constant glow until either a reasonable quantity of hot water is drawn from a tap or the water in the solar collectors loses energy and cools as the available solar energy is reduced, such as when the sun becomes lower in the sky in the late afternoon / early evening or the sky becomes very cloudy.

Refer to "[Over-temperature operation](#)" on page 15.

Rapid Pulsing

During Normal operation the red LED will rapid pulse if the temperature difference between the hot sensor and cold sensor is high due to excess heat in the solar collectors. This may not represent a fault. The rapid pulsing of the red LED will cease as the water circulates transferring the excess heat from the solar collectors to the solar storage tank and the temperature difference between the hot sensor and cold sensor reduces. This should be within four (4) to five (5) minutes, but may take up to ten (10) minutes.

If the red LED continues to emit a rapid pulse for longer than ten (10) minutes, switch off the electrical supply at the power outlet to the solar control unit for a few seconds, then switch on again. If the red LED continues to emit a rapid pulse for longer than ten (10) minutes, phone your nearest Solahart Dealer to arrange for an inspection.

Series of Flashes

If the red LED is flashing this indicates there may be a fault with the water heater. The red LED may emit from three to six flashes in each series of flashes with a 2 second interval between each series.

If the red LED emits a series of flashes, switch off the electrical supply at the power outlet to the solar control unit for a few seconds, then switch on again. If the red LED illuminates again, then count the number of flashes and phone your nearest Solahart Dealer to arrange for an inspection.

CIRCULATOR OPERATES AT NIGHT

The circulator can operate during periods of no solar energy, usually at night, under two operational modes of the water heater. This is by design and does not indicate a fault.

Freeze Protection operation: The circulator will activate (green LED rapid pulse or 3 flashes) if the water temperature in the solar collectors approaches freezing point. This occurs in very cold conditions, such as overnight and very early in the morning before sunrise. The purpose of the Freeze Protection operation is to prevent freezing of water in the solar collectors and solar pipe work. The circulator will remain on for at least nearly seven (7) minutes and until the hot sensor measures a water temperature at a safe level above freezing from the storage tank. This process will repeat whenever the water temperature in the solar collectors approaches freezing point. Refer to “Freeze Protection operation” on page 15.

Night Time Cooling operation: The circulator will activate (green LED rapid pulse or 3 flashes) if the water heater has entered Over-temperature operation during that day. This can occur during periods of higher solar energy or lower hot water usage. Excess solar energy gained will be dissipated through the solar collectors until the water temperature in the solar storage tank decreases to a desired 60°C to 70°C. The circulator may remain on for some time. Refer to “Night Time Cooling operation” on page 15.

COLLECTOR GLASS

The Solahart warranty **DOES NOT** cover breakage of solar collector glass. Check your household insurance policy covers collector glass breakage.

 **Warning:** No attempt should be made to remove or replace broken collector glass.

The collector glass is not offered as a replacement part. Should the solar collector require replacement, contact your nearest Solahart Dealer.

IF YOU HAVE CHECKED ALL THE FOREGOING AND STILL BELIEVE YOU NEED ASSISTANCE, PHONE YOUR NEAREST SOLAHART DEALER.

INSTALLATION – WATER HEATER

THIS WATER HEATER IS NOT SUITABLE FOR POOL HEATING.

INSTALLATION STANDARDS

The water heater must be installed:

- by a qualified person, and
- in accordance with the installation instructions, and
- in compliance with the Plumbing Code of Australia (PCA), Standards AS/NZS 3500.4 and AS/NZS 3000, and all local codes and regulatory authority requirements.

⚠ Warning: This water heater may deliver water at high temperature. Refer to the Plumbing Code of Australia, local requirements and these installation instructions to determine if additional delivery temperature control is required. Refer to **“Hot Water Delivery”** on page 34.

All packaging materials must be removed from the water heater prior to its installation. This includes the removal of the cardboard base of the carton from the underside of the water heater.

Advise the occupants of any inconvenience which may occur due to disconnection of existing water and electrical supplies during the installation of the water heater.

WATER HEATER APPLICATION

This water heater is designed for use in a single family domestic dwelling for the purpose of heating potable water. Its use in an application other than this may shorten its life.

If this water heater is to be used where an uninterrupted hot water supply is necessary for the application or business, then there should be back-up redundancy within the hot water system design. This should ensure the continuity of hot water supply in the event that this water heater was to become inoperable for any reason. We recommend you provide advice to the system owner about their needs and building back-up redundancy into the hot water supply system.

WATER HEATER LOCATION

The electric water heater / solar storage tank is suitable for either outdoor or indoor installation. Whether located outdoor or indoor, the water heater should be installed close to the most frequently used outlet and its position chosen with safety and service in mind.

Note: If the water heater is being installed as an electric water heater with the view of upgrading to a solar water heater at a later date, then clearance must be left on the right hand side of the water heater to allow for the installation and servicing of the solar control unit and the installation of pipework to the solar collectors.

In addition, for a solar water heater installation, consideration must also be given to the position of the solar storage tank in relation to the solar collectors. There are limitations on the maximum length of the solar hot and solar cold pipes between the solar storage tank and the solar collectors. Refer to **“Solar Collector Location”** on page 48, to **“Pipe Lengths”** on page 50 and to **“Maximum Height to Collectors”** on page 51.

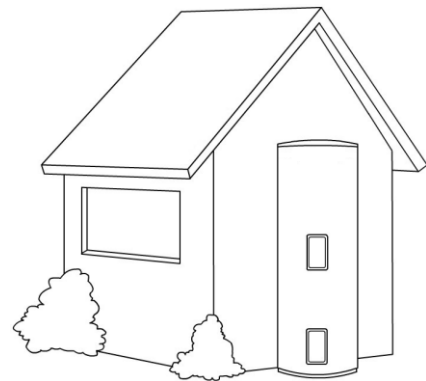

Clearance must be allowed for servicing of the water heater and solar control unit. The water heater must be accessible without the use of a ladder or scaffold. Make sure the temperature pressure relief valve lever is accessible and the front cover, thermostat, heating unit, solar control unit cover, PCB and circulator can be removed for service.

You must be able to read the information on the rating plate. If possible leave headroom of one water heater height so the anode can be inspected or replaced. Remember you may have to remove the entire water heater later for servicing.

The water heater is to be installed at ground or floor level and must stand vertically upright on a stable base as acceptable to local authorities. The base of the water heater is made of corrosion resistant material, and it may be placed directly in contact with the supporting surface. It is not necessary to allow for free air circulation under the base of the water heater.

Note: The water heater should not be placed in direct contact with a concrete surface that is less than two months old and not fully cured as this may attack the metal coating of the water heater base. A moisture barrier should be used between the two surfaces in this instance. The barrier should extend at least 100 mm from the water heater and may be trimmed after two months.

The water heater / solar storage tank and solar control unit must not be installed in an area with a corrosive atmosphere where chemicals are stored or where aerosol propellants are released, as exposure to the corrosive atmosphere may attack the materials used in the water heater / storage tank and control unit.

Remember all local authorities have regulations about putting water heaters into roof spaces.

SAFE TRAY

Where damage to property can occur in the event of the water heater leaking, the water heater must be installed in a safe tray. Construction, installation and draining of a safe tray must comply with AS/NZS 3500.4 and all local codes and regulatory authority requirements. AS/NZS 3500.4 also has particular requirements when a safe tray must be installed.

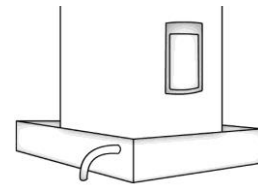

MAINS WATER SUPPLY

Where the mains water supply pressure exceeds that shown in the table, an approved pressure limiting valve is required and should be fitted as shown in the **cold water connection diagram** on page 54.

Model	270, 320
Temperature pressure relief valve setting	1000 kPa
Expansion control valve setting *	850 kPa
Maximum mains supply pressure	
With expansion control valve	680 kPa
Without expansion control valve	800 kPa
Minimum mains supply pressure	200 kPa

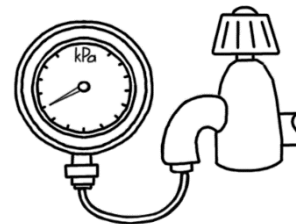

* Expansion control valve not supplied with the water heater.

TANK WATER SUPPLY

If the water heater is installed as an electric water heater and supplied with water from a tank supply and a pressure pump system is not installed, then the bottom of the supply tank must be at least 1 m above the highest point of the hot water plumbing system, including the water heater.

If the water heater is installed as a solar water heater and supplied with water from a tank supply and a minimum water supply pressure of 200 kPa at the water heater cannot be achieved, then a pressure pump system must be installed to allow the collector circuit system to operate.

Care must be taken to avoid air locks. The cold water line from the supply tank should be adequately sized and fitted with a full flow gate valve or ball valve.

REDUCING HEAT LOSSES

The cold water line to and the hot water line from the water heater must be insulated in accordance with the requirements of AS/NZS 3500.4. The insulation must be weatherproof and UV resistant if exposed.

SADDLING - PIPE WORK

To prevent damage to the cylinder when attaching pipe clips or saddles to the water heater jacket, we recommend the use of self-drilling screws with a maximum length of 13 mm. Should pre drilling be required, extreme caution must be observed when penetrating the jacket of the solar storage tank.

Note: If the cylinder is damaged as a result of attaching pipe clips or saddles to the jacket, any resultant faults will not be covered by the Solahart warranty.

ANODE

The vitreous enamel lined cylinder of the water heater is only covered by the Solahart warranty when the total dissolved solids (TDS) content in the water is less than 2500 mg/L and when the correct colour coded anode is used. If an incorrect colour coded anode is used in the water heater, any resultant faults will not be covered by the Solahart warranty. In addition, the use of an incorrect colour coded anode may shorten the life of the water heater cylinder.

The correct colour coded anode for the water supply being used must be selected and fitted to the water heater for the Solahart warranty to apply to the water heater cylinder (refer to “**Water Supplies**” on page 22 and the **Anode Selection table** on page 22). The black anode is typically fitted as standard.

If an incorrect anode is used, there is also the possibility the anode may become overactive and hydrogen gas could accumulate in the top of the water heater during long periods of no use. In areas where this is likely to occur, the installer should instruct the householder on how to dissipate the gas safely (refer to “**Caution**” on page 23).

SOLAR WATER HEATER INSTALLATION – ADDITIONAL INFORMATION

This solar water heater is designed to be installed as an electric boosted solar water heater with its booster heating unit connected to a power supply, however it may be installed with an in-series continuous flow or storage booster.

Booster Heating Unit – The booster heating unit is for heating the water at times of low solar energy gain, such as during very cloudy or rainy weather, or during the colder months. Refer to “**Connections – Electrical**” on page 58 for electrical connection requirements and control options of the booster heating unit.

In-Series Booster – If this water heater is installed with an in-series booster, then the electric booster heating unit will not need to be connected to a power supply and the references to the electric booster heating unit, thermostat and boosting controls in these installation instructions will not be applicable to the installation.

Note: AS 3498 requires that a water heater provides the means to inhibit the growth of Legionella bacteria in potable water. This solar water heater can satisfy this AS 3498 requirement provided the electric booster is energised for a sufficient period each day and the electric booster thermostat setting is 60°C or higher.

If this solar water heater is installed with an in-series continuous flow gas booster, then this requirement of AS 3498 can be satisfied provided the booster is energised, its preset outlet temperature setting is 70°C or higher and a remote temperature controller is not used.

If this solar water heater is installed with an in-series storage booster, then this requirement of AS 3498 can be satisfied provided the storage booster is energised and its thermostat setting is 60°C or higher.

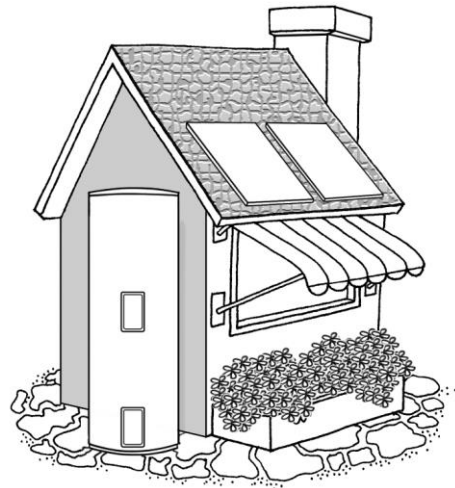

Installing the Solar Water Heater as a Pre-Heater

This solar water heater can be used as a pre-heater to a new or existing in-series booster water heater provided:

- The in-series booster water heater is;
 - thermostatically-controlled, and
 - suitable to be used as an in-series booster water heater for a solar water heater.
- The operating pressures of the two water heaters are compatible or reduced to the lower rated of the two water heaters.
- The in-series booster water heater has sufficient thermal capacity to supply the hot water requirements of the application during periods of low or no solar gain.
- A temperature-operated bypass valve is installed prior to the in-series water heater if this water heater has either an over temperature energy cut-out which can be permanently disabled by high temperature hot water or a maximum recommended inlet supply temperature less than the temperature of water which can be supplied by this solar water heater.

It will be necessary to check with the manufacturer of the in-series water heater as to its suitability for use as an in-series booster to this solar water heater.

Freeze Protection

The system has a level of freeze protection designed to guard the system against damage from freeze conditions. The system must be installed with the full length of the solar hot and solar cold pipes insulated and power must be available at the solar control unit to offer protection against freeze damage (refer to “**Warning: Plumber Be Aware**” on page 52). Freeze conditions occur below 6°C.

This model has an anti-freeze heating unit (frost element) housed under the lower front cover located at the bottom of the tank. This heating unit provides additional freeze protection to the circulating freeze protection system of the solar water heater. It does this by heating the water at the bottom of the solar storage tank at times of low cold water temperature, providing additional energy to assist in the prevention of freezing in the solar pipe work and solar collectors.

The anti-freeze heating unit is supplied with power from and controlled by the solar controller and will only be energised when the water temperature is very low and the circulator activates in the Freeze Protection operation mode. The water temperature is monitored by the cold sensor. The anti-freeze heating unit will be de-energised when either the frost mode is shut down or the water temperature has risen by a few degrees.

It is essential the electrical circuit to the solar control unit is continually turned on if there is a risk of freezing, for the anti-freeze heating unit to operate and offer additional freeze protection.

The system is not recommended for installation above 600 metres altitude. A system with a frost element has NO WARRANTY for freeze damage when installed above 600 metres altitude or if the solar hot and solar cold pipes are not insulated in accordance with the installation instructions or if power is not available at the solar control unit (refer to “**Terms of the Solahart Warranty**” on page 4).

Note: The Solahart warranty against freeze damage applies only to systems installed in Australia.

Victorian Installers

Notice to Victorian Installers from the Victorian Building Authority if this solar water heater is installed in a new Class 1 dwelling in the State of Victoria. The system model number is to be recorded on the Certificate of Compliance.

It is also a requirement to provide the householder with permanent documentation recording the system model number exactly as it is shown in the ‘VEET Product Register’ published by the Essential Services Commission in Victoria. See www.veu-registry.vic.gov.au/Public/ProductRegistrySearch.aspx. This documentation may be in the form of an indelible label adhered to the solar storage tank, or other suitable form placed in an accessible location, such as the meter box, for later inspection.

HOT WATER DELIVERY

⚠ Warning: This water heater can deliver hot water at a temperature up to 70°C when installed as an electric water heater, and when installed as a solar water heater up to 75°C during normal operation and on occasion the water temperature may exceed 75°C. These temperatures are sufficiently hot to cause severe scalding. Water at this temperature may be plumbed to fixtures where water hotter than 50°C is allowed, such as the kitchen and laundry.

The installing plumber may have a legal obligation to ensure the installation of this water heater meets the water temperature delivery requirements of the Plumbing Code of Australia so that heated water delivered to fixtures and appliances used primarily for personal hygiene is at a temperature which is unlikely to scald.

It is necessary and we recommend that a temperature limiting device be fitted between the water heater and the fixtures and appliances used primarily for personal hygiene such as in a bathroom, ensuite, public amenities or other ablution areas, to reduce the risk of scalding.

The temperature limiting device must be of a type suitable for use with a solar water heater if the water heater is installed as a solar water heater. If the water heater is installed as a standard electric water heater, it is recommended the temperature limiting device be suitable for use with a solar water heater to cater for an upgrade to a solar water heater in the future. Refer to the manufacturer’s specifications of the temperature limiting device.

Where a temperature limiting device is installed adjacent to the water heater, the cold water line to the temperature limiting device can be branched off the cold water line either before or after the isolation valve, pressure limiting valve and non-return valve to the water heater. If an expansion control valve is required, it must always be installed after the non-return valve and be the last valve prior to the water heater.

Solar control unit, PN 052302 (supplied in the solar controller kit PN 299316) contains a non-return valve at the inlet to the circulator. For a water heater fitted with this solar control unit, it is not required to install a non-return valve after the cold water branch to a temperature limiting device if the branch line is after the isolation valve, pressure limiting valve and non-return valve to the water heater.

If a pressure limiting valve is installed on the cold water line to the solar water heater and the cold water line to a temperature limiting device branches off before this valve or from another cold water line in the premises, then a pressure limiting valve of an equal pressure setting may be required prior to the temperature limiting device.

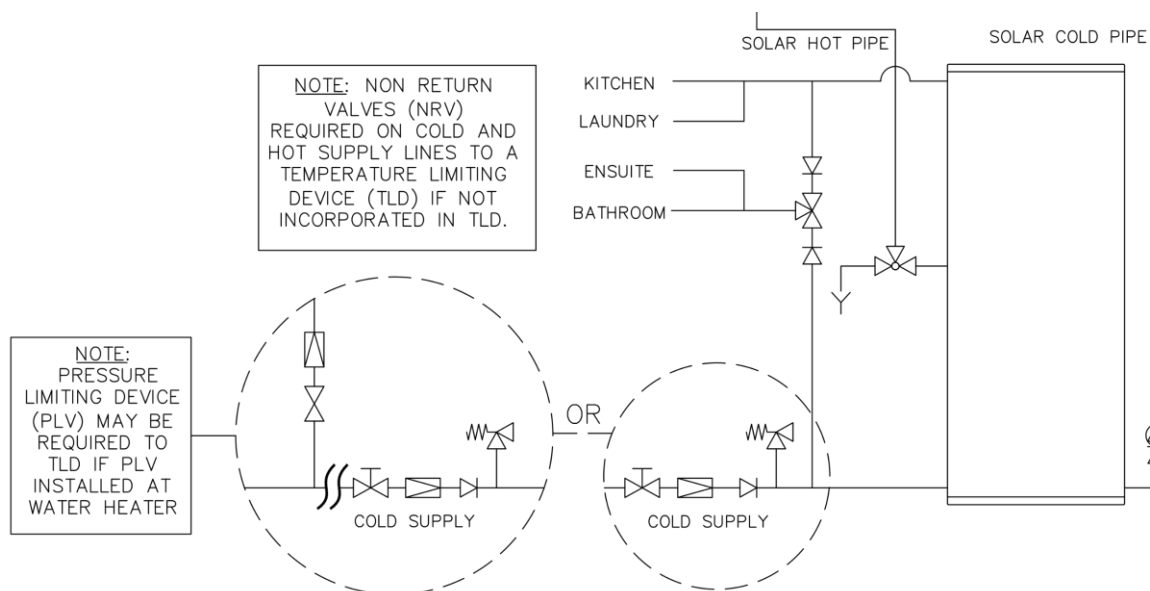

Two Temperature Zones Using a Temperature Limiting Device – Solar Water Heater

CIRCULATED HOT WATER FLOW AND RETURN SYSTEM

The water heater when installed as either a standard electric water heater connected to an Off-Peak electricity supply or as a solar water heater, should not be installed as part of a circulated hot water flow and return system in a building. The benefits of the Off-Peak or controlled electricity supply or of the solar gain will be significantly reduced.

If a circulated flow and return system is required, it is necessary to install a secondary water heater supplied from this water heater. The flow and return lines connect to the secondary water heater, not this water heater. The secondary water heater makes up for the pipe heat loss in the flow and return system and must be able to provide a hot water outlet temperature of at least 60°C.

Note: The thermostat of the secondary water heater must be set to at least 60°C. The return water temperature to the water heater must not be less than 55°C. If it falls below 55°C, the thermostat setting of the secondary water heater must be set to above 60°C to ensure the return water temperature is not less than 55°C.

Refer to the Circulated Hot Water Flow and Return System diagrams for **Off Peak Standard Electric Water Heater** and **Solar Water Heater** on page 35.

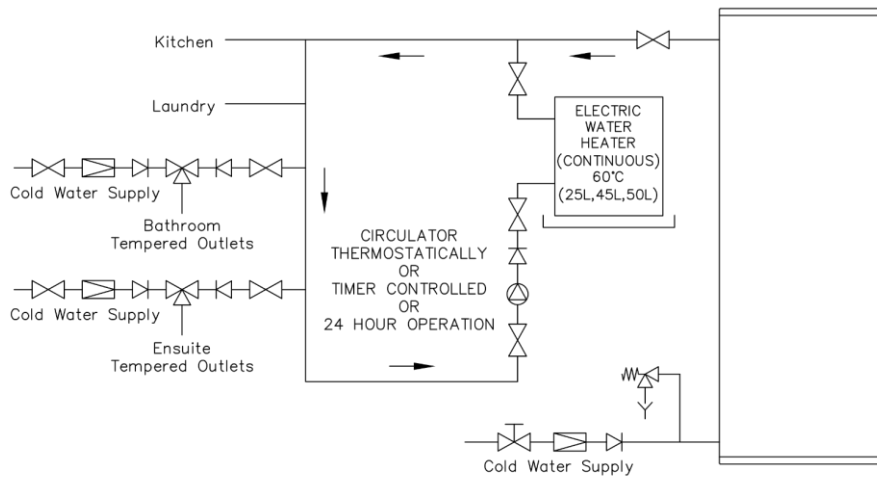

NOTE: A PLV IS REQUIRED TO BE INSTALLED ON THE COLD SUPPLY LINE TO THE TEMPERING VALVE IF A PLV IS INSTALLED ON THE COLD SUPPLY LINE TO THE WATER HEATER.

**Circulated Hot Water Flow and Return System
Off Peak Standard Electric Water Heater**

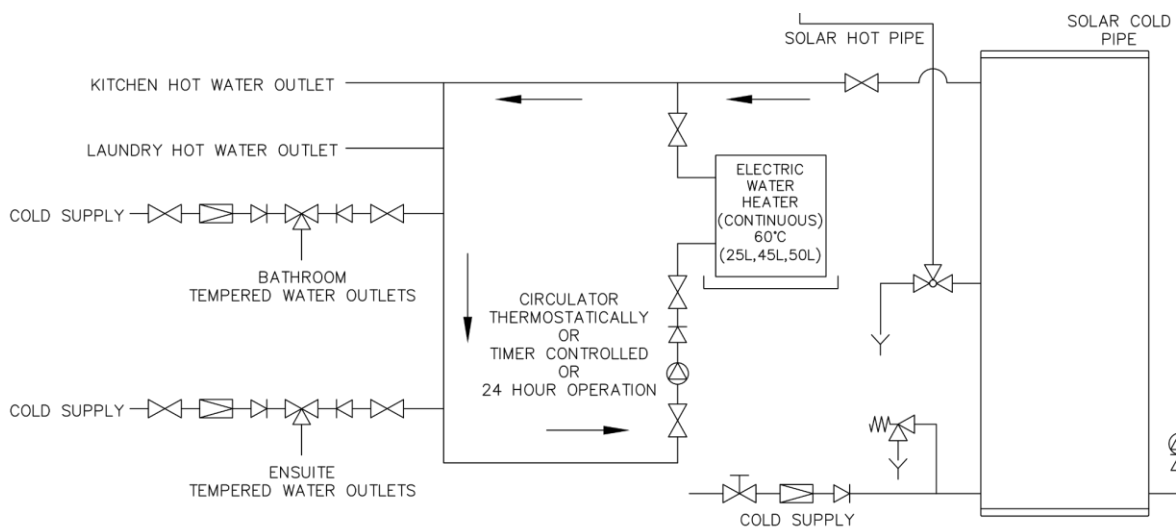

NOTE: A PLV IS REQUIRED TO BE INSTALLED ON THE COLD SUPPLY LINE TO THE TEMPERING VALVE IF A PLV IS INSTALLED ON THE COLD SUPPLY LINE TO THE WATER HEATER.

**Circulated Hot Water Flow and Return System
Solar Water Heater**

In-series Boosting – Solar Water Heater

If a solar water heater does not have its electric heating unit connected for in-tank boosting and is installed as a solar pre-heater to an in-series booster water heater, then the booster water heater can be used as the secondary water heater so long as it is able to provide a minimum hot water outlet temperature of at least 60°C and it is not connected to an Off-Peak or time controlled electricity supply. It is necessary to connect the flow and return lines to the in-series booster and not to the solar storage tank.

Refer to the diagram **Circulated Hot Water Flow and Return System – Solar Water Heater with In-series Boosting** on page 36.

If the in-series water heater is a continuous flow water heater, the circulator must be:

- sized and set to provide a minimum flow rate of 3.0 L/min through the circulated hot water flow and return system, and
- either thermostatically and / or timer controlled.

The circulator **must not** be set to operate continuously, i.e. 24 hours per day.

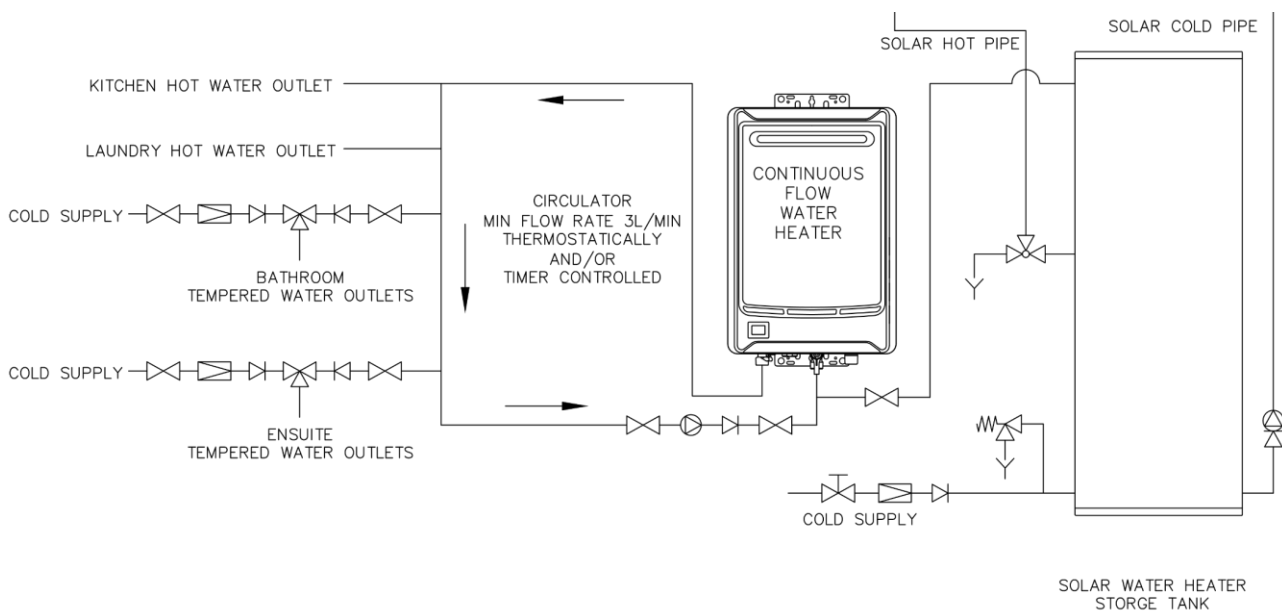

Circulated Hot Water Flow and Return System – Solar Water Heater with In-series Boosting

Temperature Settings

- AS 3498 requires that a water heater provides the means to inhibit the growth of Legionella bacteria in potable water. To meet this requirement of AS 3498:
 - A solar storage tank with its electric heating unit connected for in-tank boosting, and the secondary water heater must always have their thermostats set to at least 60°C
 - An in-series storage water heater must always have its thermostat set to at least 60°C
 - An in-series continuous flow water heater must always have its preset outlet temperature setting set to at least 70°C
- Water should not be circulated from a water heater with a temperature setting of less than 60°C.
- The return water temperature to the water heater must not be less than 55°C.

If the return water temperature decreases by more than 5°C due to heat loss from the hot water ring main, the preset outlet temperature setting or thermostat setting of the secondary water heater or in-series water heater must be set to above 60°C to ensure the return water temperature is not less than 55°C.

Temperature Limiting Device

A temperature limiting device cannot be installed in circulated hot water flow and return pipe work. The tempered water from a temperature limiting device cannot be circulated. Where a circulated hot water flow and return system is required in a building, a temperature limiting device can only be installed on a dead leg, branching off the circulated hot water flow and return pipe.

If circulated tempered water were to be returned back to the water heater, depending on the location of the return line connection on the water supply line to the water heater, then either:

- water will be supplied to the cold water inlet of the temperature limiting device at a temperature exceeding the maximum recommended water supply temperature, or
- when the hot taps are closed no water will be supplied to the cold water inlet of the temperature limiting device whilst hot water will continue to be supplied to the hot water inlet of the temperature limiting device.

These conditions may result in either water at a temperature exceeding the requirements of AS/NZS 3500.4 being delivered to the hot water outlets in the ablution areas, or the device closing completely and not delivering water at all, or the device failing. Under either condition, the operation and performance of the device cannot be guaranteed.

DIMENSIONS AND TECHNICAL DATA – ELECTRIC WATER HEATERS

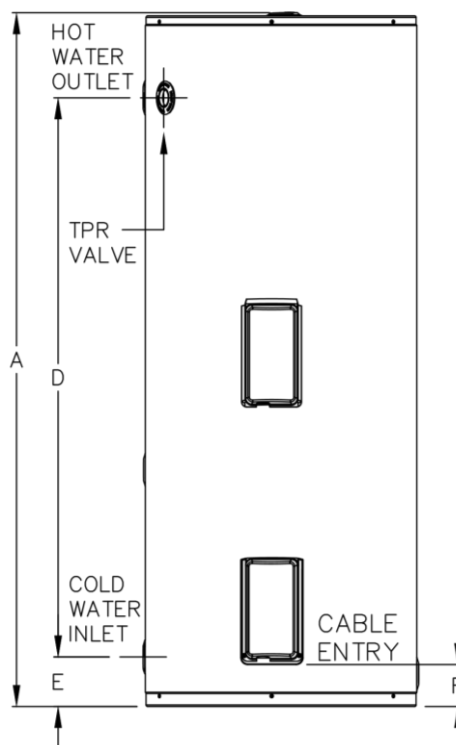
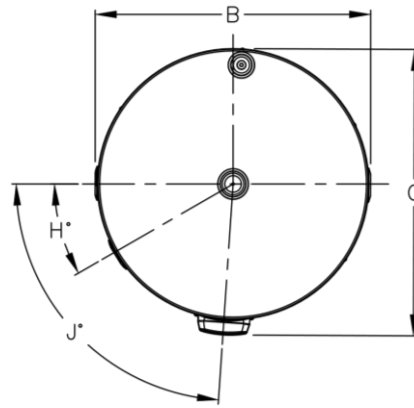

Electric Models	Nominal Storage Capacity	Tank Mass (kg)	
		Empty	Full
270RMX36E	270 litres	84	354
320RMX36E	320 litres	94	430

Dimensions (mm)	A	B	C	D	E	F	H	J
270RMX36E	1395	640	680	1112	73	103	32°	88°
320RMX36E	1640	640	680	1317	113	103	32°	88°

The tank model number has a three character suffix.

A two digit suffix to denote the heating unit size (second and third last characters), where 36 = 3.6 kW (bottom heating unit standard electric water heater), and

A one letter suffix to denote its installation configuration type (last character), where E = standard electric water heater.

Technical data is subject to change.

DIMENSIONS AND TECHNICAL DATA – SOLAR WATER HEATERS

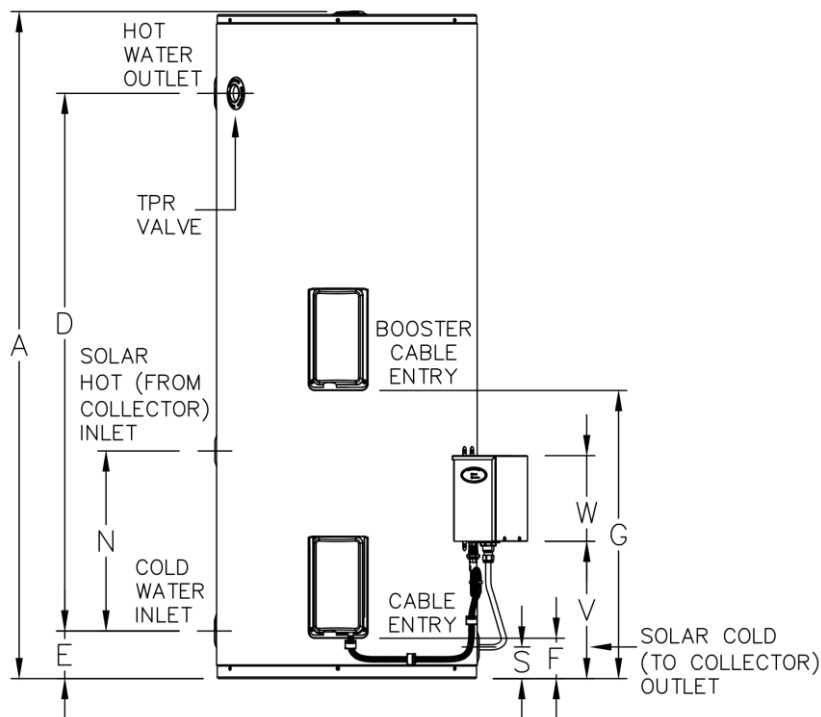
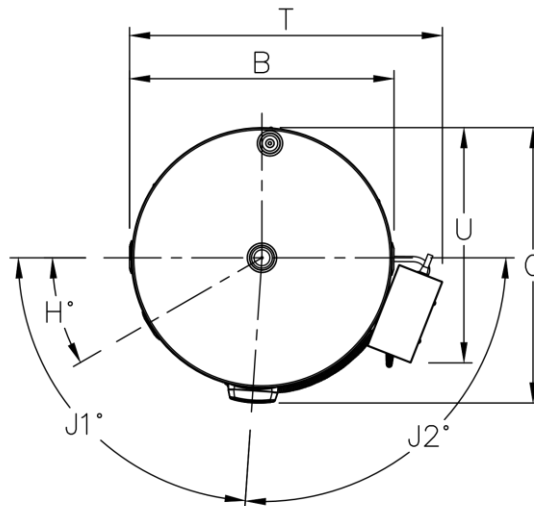

Solar Models	Nominal Storage Capacity	Boost Capacity	Tank Mass (kg)	
			Empty	Full
270RMX36S	270 litres	140 litres	82	352
320RMX36S	320 litres	170 litres	92	417

Dimensions (mm)	A	B	C	D	E	F	H	J1	J2	N	S	T	U	V	W
270RMX36S	1395	640	680	1112	73	103	32°	88°	92°	412	73	765	647	320	210
320RMX36S	1640	640	680	1317	113	103	32°	88°	92°	441	73	765	647	320	210

The tank model number has a three character suffix.

A two digit suffix to denote the booster heating unit size (second and third last characters), where 36 = 3.6 kW (top heating unit), and

A one letter suffix to denote its installation configuration type (last character), where S = solar.

Technical data is subject to change.

TYPICAL INSTALLATION STANDARD ELECTRIC WATER HEATER – OUTDOOR LOCATION

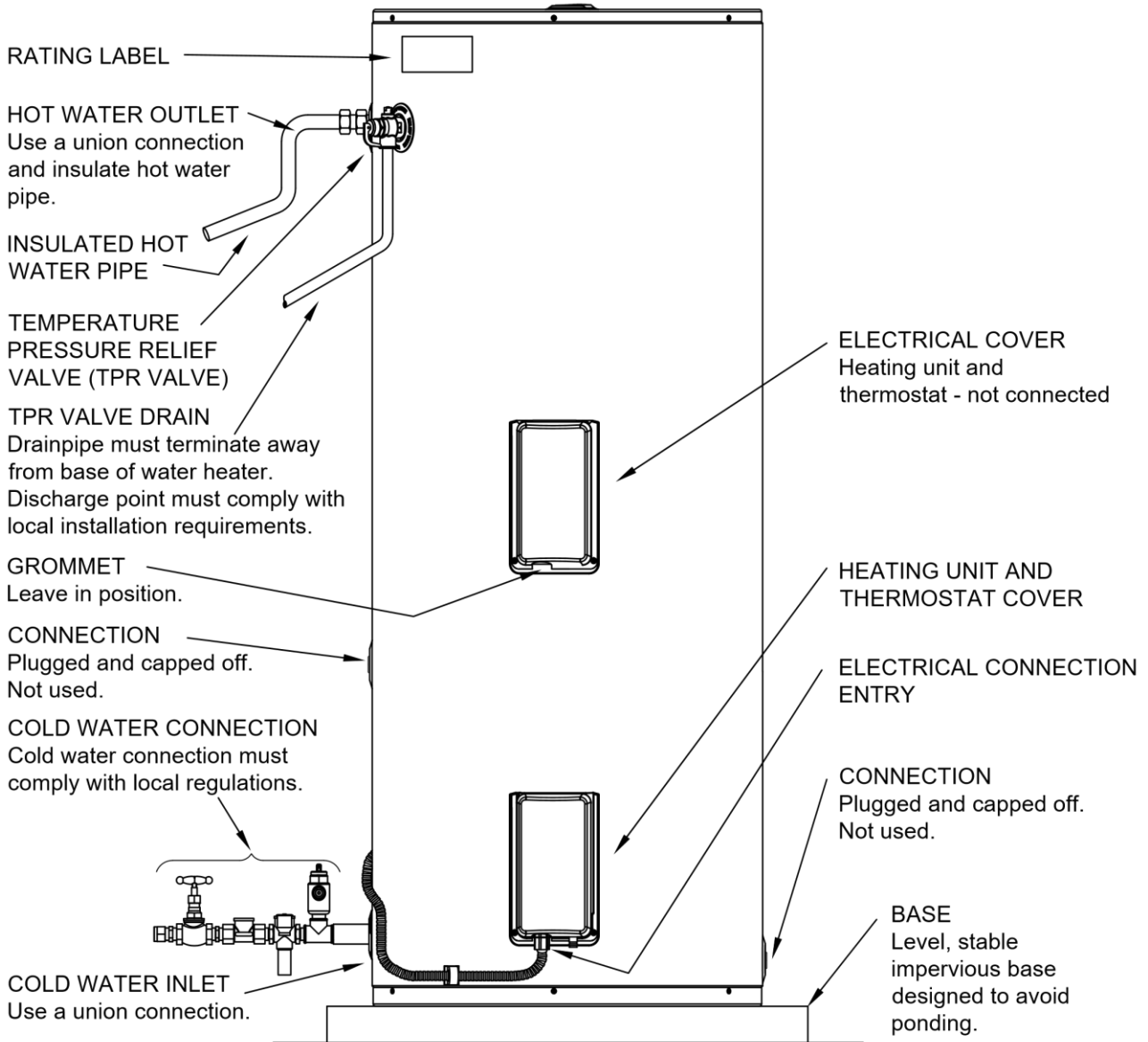

TYPICAL INSTALLATION STANDARD ELECTRIC WATER HEATER – INDOOR LOCATION

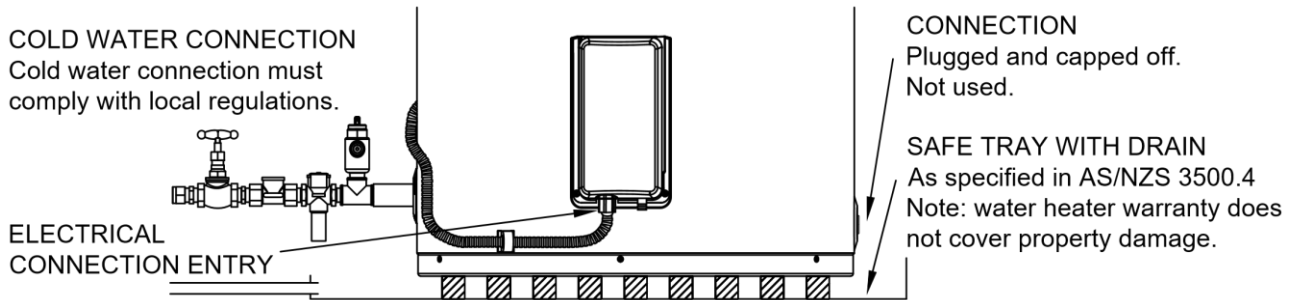

TYPICAL INSTALLATION SOLAR WATER HEATER – OUTDOOR LOCATION

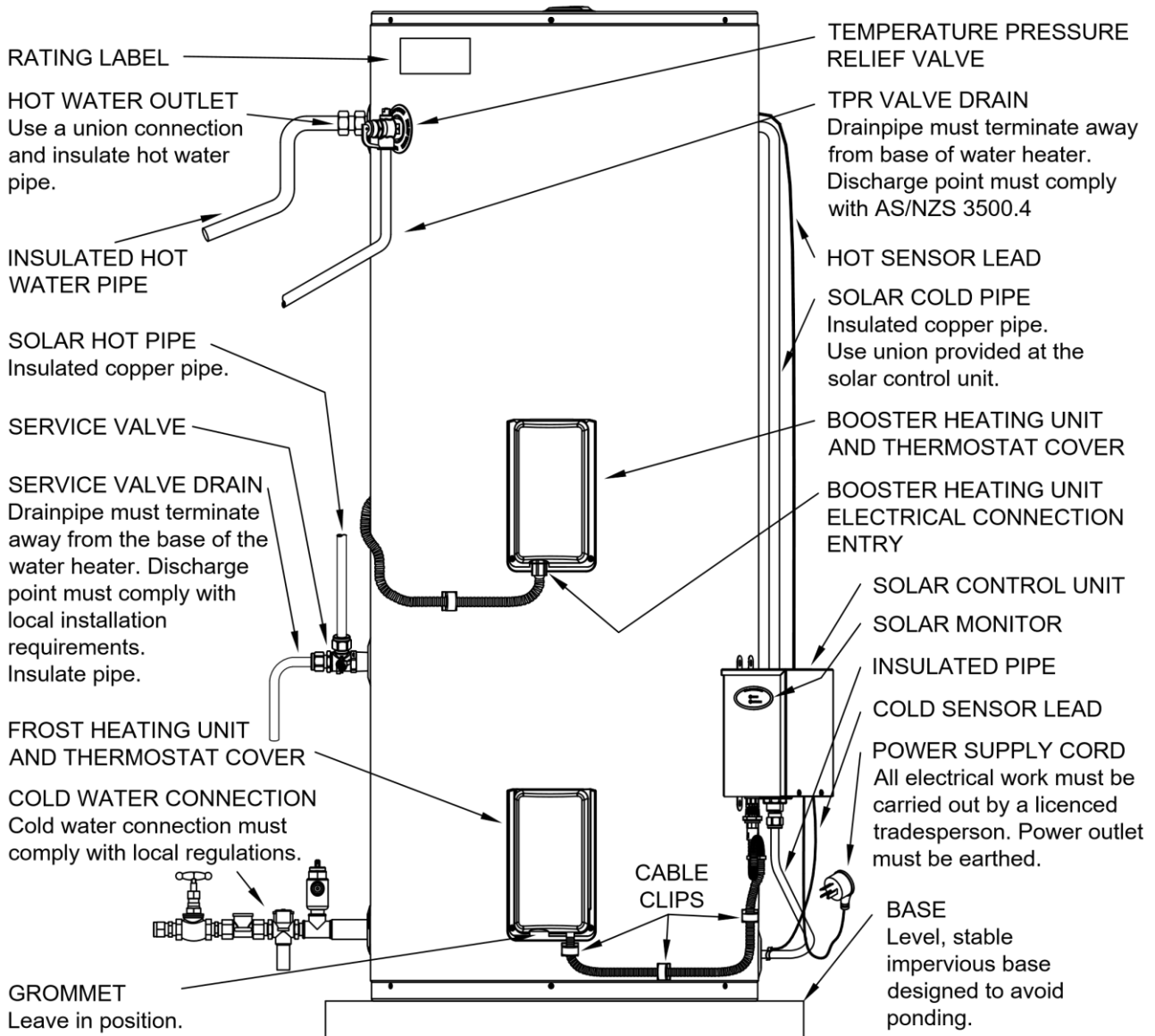

TYPICAL INSTALLATION SOLAR WATER HEATER – INDOOR LOCATION

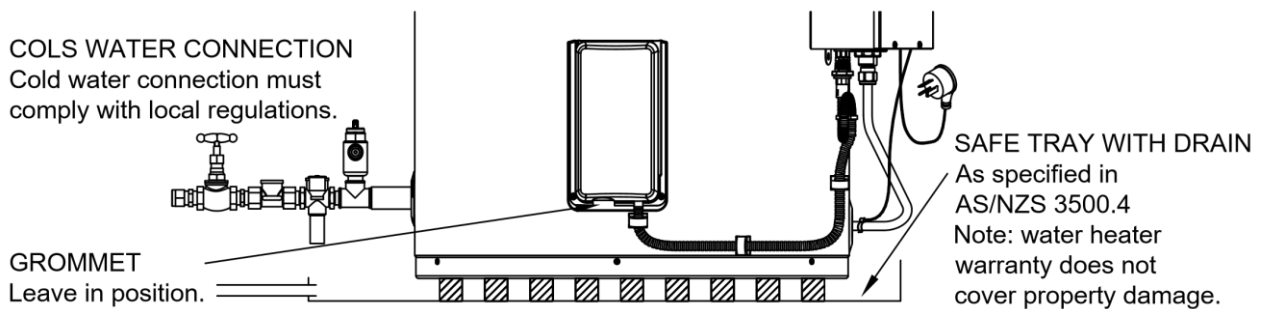

INSTALLATION – SOLAR CONTROL UNIT

The solar control unit is designed to be mounted on the side of the solar storage tank, with its location above and offset from the solar cold water outlet. The solar control unit and components to enable the connection of the collector circuit pipe work to the tank are supplied in a kit (PN 299316) separate to the tank. The solar control unit (PN 052302) contains a non-return valve at the inlet to the circulator.

The solar control unit, supplied with a 1.8 metre power cord, requires a 220 V - 240 V a.c. 50 Hz general purpose outlet (GPO) located within 1.2 metres of its installation. The GPO must have a continuous power supply originating from a circuit other than the water heater circuit. The GPO is required to be weatherproof if installed outdoors (refer to “Connections – Electrical” on page 58).

The solar control unit incorporates a circulator to circulate the water between the solar storage tank and the solar collectors. The solar control unit controls the operation of the circulator and an anti-freeze heating unit installed in the lower part of the solar storage tank, and governs the flow rate through the collector circuit. This is achieved via the hot and cold sensors and differential controller programming providing control over the operation of the circulator and the anti-freeze heating unit.

There is no provision for nor is adjustment to the solar control unit required.

Part No	Kit Components and Description - Controller Kit 299316	Qty
120635	Installation instructions solar controller solar ready split frost	1
122330	Instruction sheet guide	1
052302	Control unit assembly solar ready frost element	1
080031	Screw Philips pan head No 8 x 13 mm	7
103626	Front lower cover assembly solar upgrade	1
053187	Clip cable flexicon FCL13B	3
220654	Valve service 3-way solar assembly BV503, consisting of: 1 x service valve 3-way solar 2 x nut compression 1/2" 2 x olive compression copper 1/2"	1
331658	Union body R 3/4 M x DN15 olive	1
331655	Nut compression DN15 Rye 10090	1
331656	Olive compression copper DN15	1
070897	Pipe cold loline preformed tube 1/2" x 350 mm long	1
090283	Insulation pipe 13 mm thick 13 mm ID x 350 mm long 70 mm slit	1
090281	Insulation pipe 13 mm thick 35 mm ID x 80 mm long	1
080228	Cable tie black 250 – 300 mm x 4.8 mm	5
088065	Fitting union male 1/2" C x 1/2" C Rye 4930, consisting of: 1 x hex nipple brass 1/2" x 1/2" 2 x nut compression 1/2" 2 x olive compression copper 1/2"	1

Notes

- Care must be taken when mounting the solar control unit and the conduit clips to the side of the solar storage tank. Use the self-tapping screws provided. If the cylinder is damaged as a result of mounting the solar control unit or conduit clips to the jacket, any resultant faults will not be covered by the Solahart warranty.
- All pipe work must be purged and cleared of foreign matter before connection and before attempting to operate the water heater.
- It is important to connect the solar hot and solar cold pipes to the correct connections at the solar storage tank and solar control unit.
- Connect the solar hot and solar cold pipes to the solar storage tank and solar control unit using only the fittings supplied.
- All olive compression fittings must use brass or copper olives.
- Use an approved thread sealant such as Teflon tape on all threaded joints. Conetite or O-ring fittings do not require a thread sealant.

SOLAR STORAGE TANK WITH RAISED SOLAR HOT INLET

Numbers in parentheses refer to items on diagram on page 44 for a **frost element model**.

To mount the solar control unit on the solar storage tank and connect the solar cold pipe:

- Fit the union R 3/4 M x DN15 (2) to the solar cold water outlet of the solar storage tank.
- Connect the DN15 preformed pipe (3), pre-insulated with the 350 mm long x 13 mm diam insulation (10), to the union (2) at the solar cold water outlet and finger tighten using the compression nut (4) and olive (5) provided, ensuring the straight end is orientated upwards.
- Undo the compression nut (4) and olive (5) from the underside of the solar control unit (6) and place over the end of the DN15 preformed pipe (3).
- Locate the solar control unit (6) in an upright position by connecting the DN15 preformed pipe (3) to the union at the inlet of the circulator on the underside of the solar control unit and finger tighten using the compression nut (4) and olive (5).
- Secure the solar control unit (6) to the solar storage tank using the four self-tapping screws (7) provided.
- Tighten the compression nuts (4) on both ends of the preformed pipe (3) using a spanner.
- Disassemble the fitting union (1). Place a compression nut and olive over the end of the copper pipe protruding from the side of the solar control unit (6) and the other compression nut and olive over the end of the solar cold pipe (to the collector).
- Using two spanners, connect the solar cold pipe (to the collector) to the pipe from the solar control unit (6) using the nipple from the fitting union (1) and the compression nuts and olives.

⚠ Warning: Do not twist or rotate the outlet pipe from the solar control unit (6). One spanner must always be on the union body and remain stationary when tightening or loosening the compression nuts.

Refer to the warning label (16) on the solar control unit.

Note: A press type fitting **must not** be used to join the solar cold pipe to the pipe from the solar control unit.

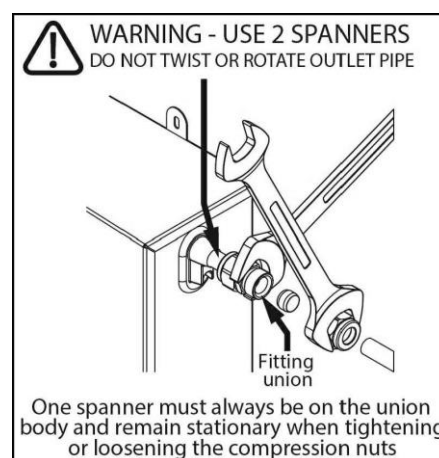

warning label

- Clip the cold sensor (8) over the end of the preformed pipe adjacent to the union (2) at the solar cold outlet connection. It is recommended to position the cold sensor on the underside of the pipe and point the sensor lead away from the tank. Refer to the exploded view **diagram** on page 44 for position.
- Wrap the slit end of the pipe insulation (10) around the lower end of the preformed pipe (3), cold sensor (8) and union (2), with the slit side around the cold sensor, and secure with two cable ties (12) allowing for the sensor lead to penetrate through the insulation. Refer to the exploded view **diagram** on page 44.
- Connect the hot sensor lead from the solar collector installation to the hot sensor cable connector at the side of the solar control unit (6). The hot sensor lead is supplied in the collector installation kit and the procedure for its installation is in the collector installation kit's installation instructions. Bundle up any excess hot sensor lead and tie off in a location where it won't sustain damage, such as tied to the outside of the insulation on the solar cold pipe.

Note: Ensure the hot sensor lead is not in direct contact with the solar hot or solar cold pipe work at any point of the collector circuit, otherwise damage to the sensor lead can occur due to the high temperatures which can be experienced within the pipe work. Damage to the hot sensor lead can result in solar gain not being achieved and the freeze protection system being rendered inoperative. The hot sensor lead may be cable tied to the outside of the insulation on the solar pipe work.

To connect the solar hot pipe to the solar storage tank:

- Fit the service 3-way solar valve assembly (9) to the solar hot water inlet of the solar storage tank. Ensure the service valve inlet is pointing vertically upwards or horizontally towards the rear of the storage tank so the opening and closing device remains easily accessible. Refer to the **diagram** on page 44 for position.
- Connect the solar hot pipe (from the collector) to the inlet of the service valve assembly (9) using the compression nut and olive provided with the valve.

- Connect a DN15 copper drain line to the service valve drain outlet using the compression nut and olive provided with the valve. The drain line must carry the discharge clear of the water heater and solar control unit and safely to drain. Refer to the **diagram** on page 44 for position and to **“Service Valve Drain”** on page 57.
- Insulate the drain line from the service valve (9) with closed cell type insulation or similar (minimum thickness 13 mm). The insulation must be weatherproof and UV resistant if exposed.
- After the collector circuit has been purged of air (refer to **“Bleeding The Solar Collectors”** on page 64), insulate the service valve assembly (9) from the solar tank to the drain line of the service valve with the 80 mm long x 35 mm ID piece of insulation (11) and secure with two cable ties (12).

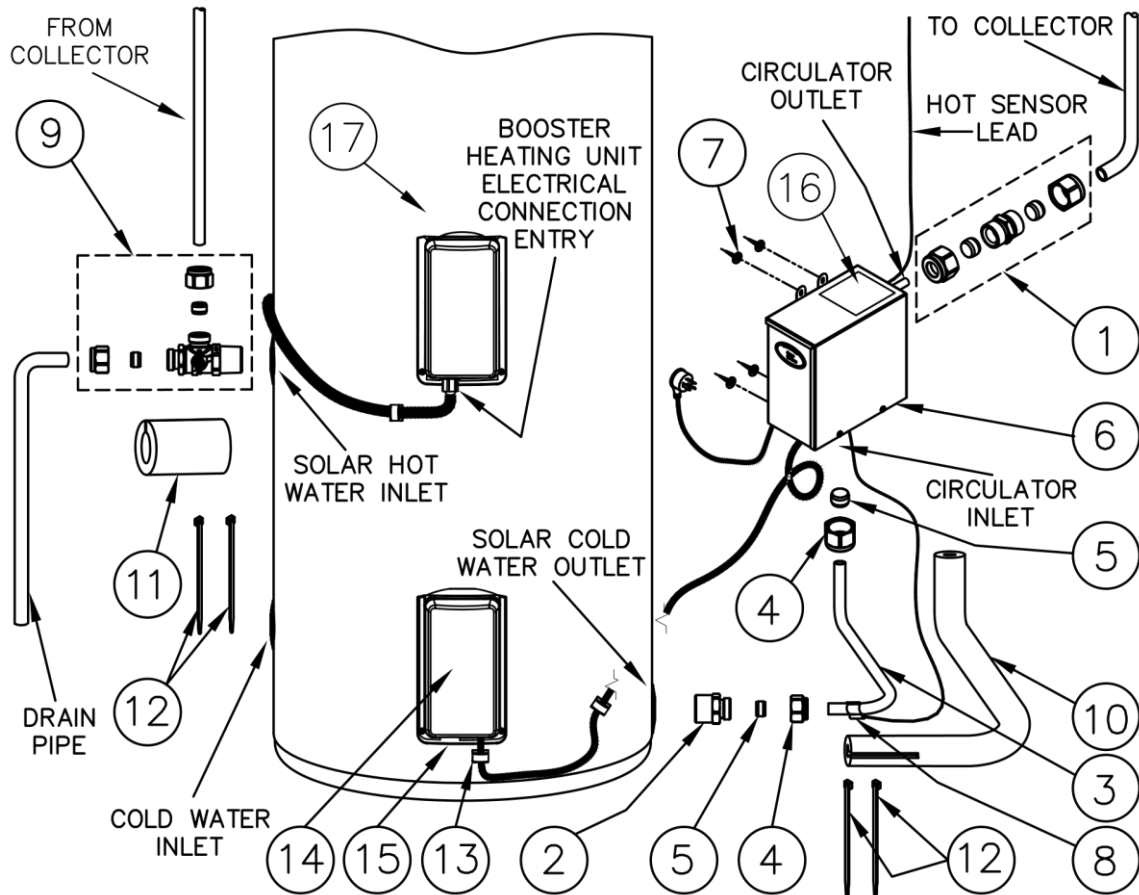

SUPPLIED IN SOLAR CONTROL UNIT KIT (299316)

1. Fitting union male 1/2" C X 1/2" C
2. Union R 3/4 M x DN15 olive
3. Preformed pipe DN15
4. Compression nut
5. Olive
6. Solar control unit
7. Screws
8. Cold sensor and clip
9. Valve service 3-way solar assembly
10. Insulation 350 mm long x 13 mm ID
11. Insulation 80 mm long x 35 mm ID
12. Cable tie
13. Conduit clip
14. Front cover (lower)
15. Grommet
16. Warning label

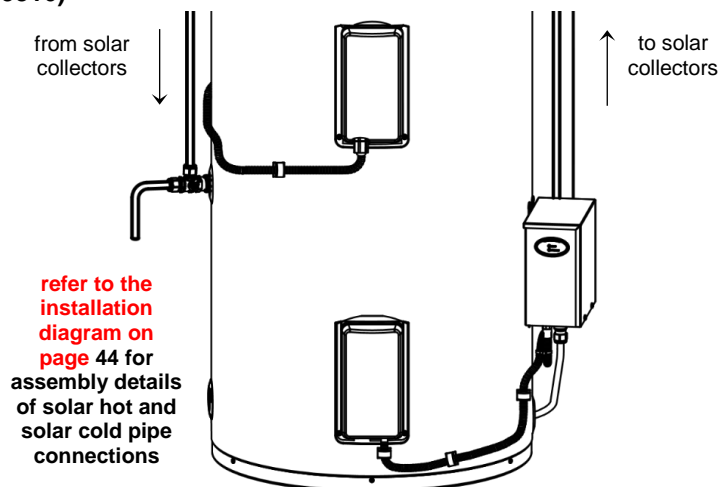

Solar Storage Tank (with Frost Element) with Solar Control Unit

To connect the solar controller wiring harness and conduit to the solar storage tank:**⚠ Warnings – Risk of Electric Shock**

- **Warning:** If mains power is already connected to the water heater, switch off power at the water heater isolating switch before removing the lower front cover.
- **Warning:** The following steps to connect the solar controller wiring harness and conduit to the solar storage tank must be completed before unwrapping the cover from the power plug and inserting the plug into the socket-outlet.

Power to the solar control unit must only be switched on after the solar controller wiring harness and conduit have been connected to the solar storage tank and the solar water heater system has been filled with water. Refer to **“To Fill And Turn On The Water Heater”** on page 63.

Refer also to the **wiring harness and conduit connection diagram** on page 46.

- Remove the lower front cover from the solar storage tank. Set aside the screws. Discard the front cover, this will be replaced by a new front cover supplied in the solar controller kit.
- Remove the 4 pin connector plug from the 10 pin connector on the bottom tab of the electrical opening.
- Remove the 10 pin connector from the tab of the electrical opening and discard.
- Fit one of the conduit clips (13) directly beneath the penetration in the tab for the 4 pin connector with a self-tapping screw (7) provided in the controller kit. This will correctly align the conduit from the solar controller when it is secured.
- It is not necessary to cut the cable tie holding the loop in the conduit beneath the solar controller, as the conduit is long enough to reach the electrical opening. Maintaining the loop assists in keeping the conduit clear of the ground or floor upon completion of the installation.
- Connect the 4 pin connector on the conduit from the solar control unit (6) to the tab of the electrical opening by sliding it into the two grooves on the tab.
- Connect the 4 pin connector plug to the 4 pin connector. Ensure they are fully engaged.
- Connect the Earth wire of the solar controller cable to the earth tab and the Active and Neutral wires of the solar controller cable to the terminal block.
- Check the wiring connections are secure, then position all wiring neatly inside of the electrical opening.
- Place the new front cover (14) supplied in position over the electrical opening and secure with the two screws.
 - This cover must replace the original lower front cover on the solar storage tank when the electrical cable wiring harness from the solar control unit is connected to the tank.
 - The new lower front cover contains a grommet (15) fitted in the left hand opening at the bottom underside of the cover. This opening is not used and the grommet must be left in position to maintain the IP rating of the solar storage tank.
- Position the remaining two conduit clips (13) to achieve approximate equidistant spacing between the first clip and the solar controller and fit with the self-tapping screws (7) provided in the controller kit.
 - Secure the conduit to the side of the solar storage tank with the three conduit clips (13).
 - Ensure the conduit is kept clear of the ground or floor.

For further information and instructions on the solar control unit (6) and its connection to power, refer to **“Solar Control Unit”** on page 60.

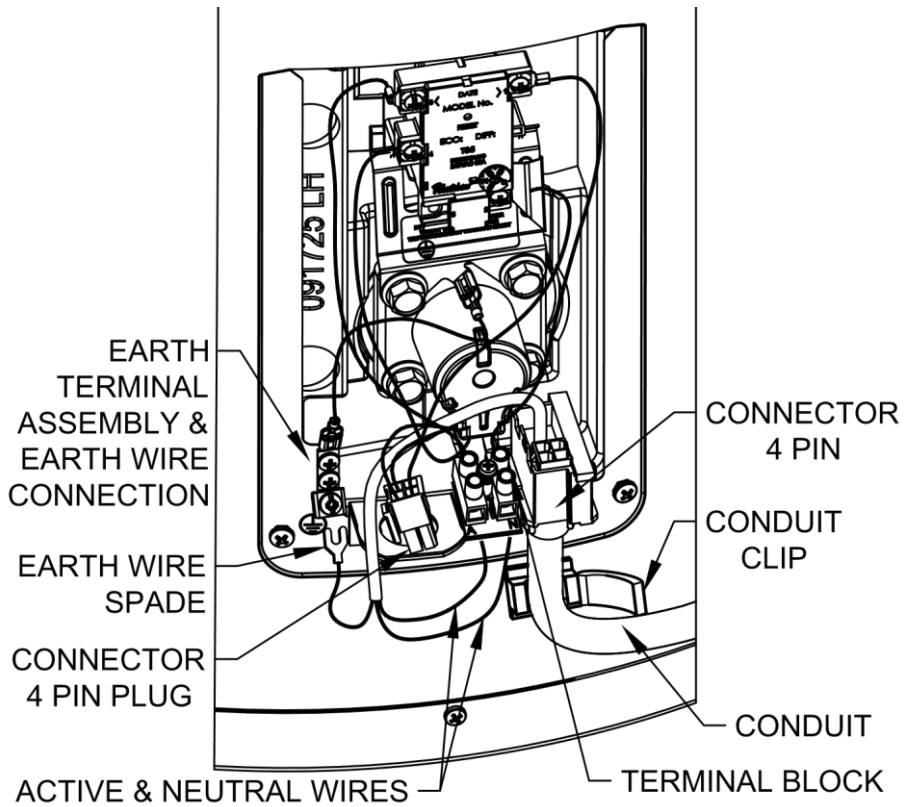

exploded view

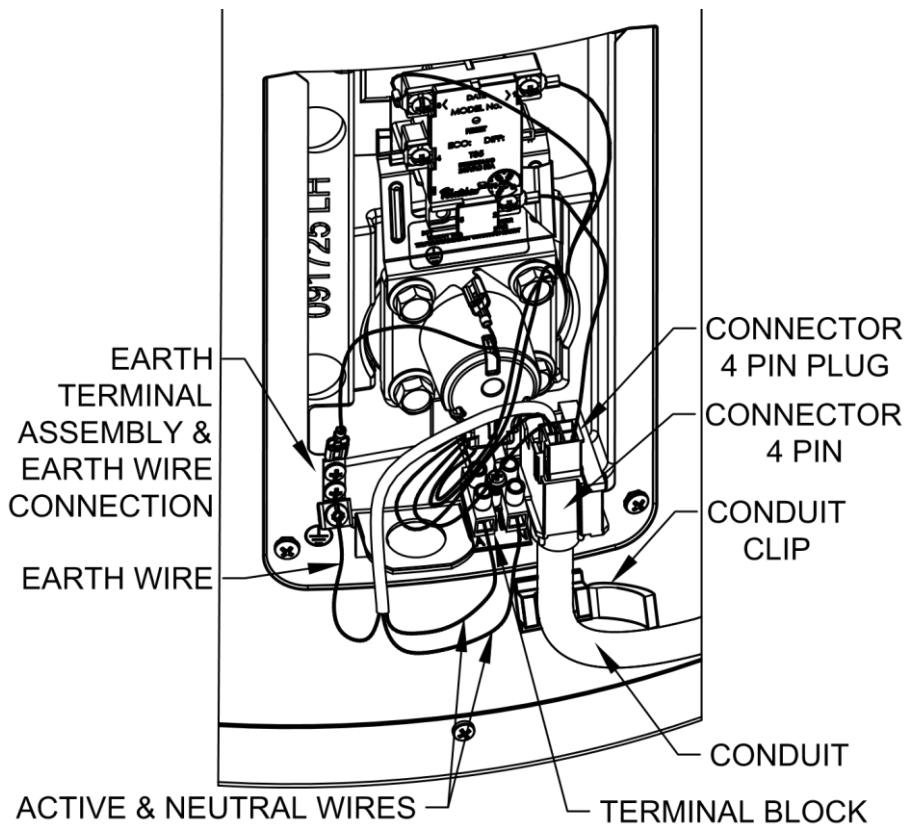

assembled view

wiring harness and conduit connection

INSTALLATION – SOLAR COLLECTORS

SOLAR COLLECTORS

The system is suitable for installation with Solahart L, LCS or CSA2007 solar collectors.

In Australia, systems with L solar collectors are suitable for installation in all climate zones. Collectors installed at an orientation greater than 60° from the equator may require an additional collector to ensure adequate solar performance.

In Australia for climate zones 1, 2, and 3 there is a risk that systems with selective surface LCS or CSA2007 solar collectors may over perform. In these zones, systems with LCS or CSA2007 solar collectors should be installed at orientations between 60° and 90° from true north only.

In climate zone 4, systems with selective surface LCS or CSA2007 solar collectors provide optimum performance compared with non-selective surface collectors, particularly in the months of lower solar radiation.

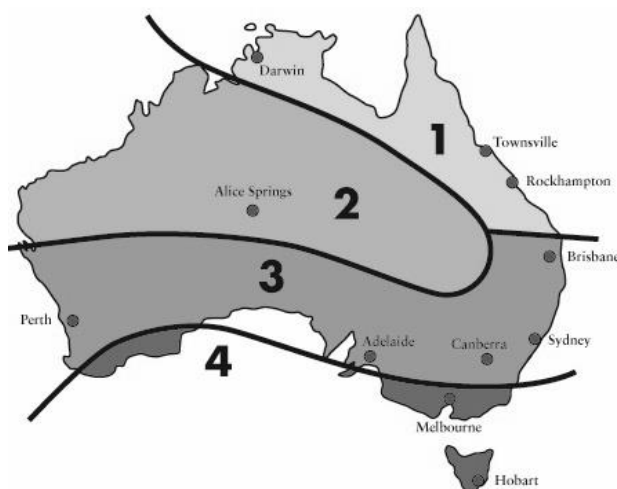

IMPORTANT NOTES

- Working on roofs is and should always be considered a hazardous activity, particularly early in the morning, late in the evening, when the roof is wet or during and after periods of rain.
- All work must be carried out in accordance with Local, State and Federal Occupational Safety, Health and Welfare Regulations. In particular, the requirements for safety whilst manual lifting, working at heights and on roofs.
- Installers must be competently trained in:
 - Height Hazard Assessment
 - Working at Height Procedures
 - Assessment / Use / Wearing of correct height safety equipment (harnesses etc.)
 - All other relevant safety factors specific to the installation and maintenance work to be compliant with suitable Occupational, Health and Safety Regulations / Codes.
- All relevant permits shall be obtained from the regulatory authorities before commencing work to install the solar hot water system.
- All work carried out must be performed by appropriately qualified tradespeople or be suitably supervised for trades assistant duties.
- Every care must be taken to protect and warn occupants of the building and the public from personal injury which may occur from falling tools, roof materials, fittings or any other hazards of a general nature.

SOLAR COLLECTOR LOCATION

Consideration must be given to the position of the solar collectors in relation to the solar storage tank. There are limitations on the maximum length of the solar hot and solar cold pipes between the solar storage tank and the solar collectors. Refer to “Water Heater Location” on page 30, to “Pipe Lengths” on page 50 and to “Maximum Height to Collectors” on page 51.

The solar collectors must be installed in a shade free position. The surrounds should be checked for higher buildings or trees which may cause shade at other times of the year and for small trees which may grow and shade the solar collectors in the future.

The installation must comply with the requirements of either AS/NZS 3500.4 and all local codes and regulatory authority requirements. Refer to the installation instructions supplied with the collector kit for details on the installation of the solar collectors.

ROOF STRENGTH

The installer must ensure the structural integrity of the building is not compromised by the solar water heater installation and the roof structure is suitable to carry the full weight of the solar collectors and frame (if one is installed). If in any doubt of the construction or the condition of the roof, the roof should be suitably strengthened. Consult a structural engineer. Each solar collector and its fittings weigh approximately 34 kg (L – 2.0 m² collector) or 36 kg (LCS – 2.0 m² collector) or 41 kg (CSA2007 – 2.0 m² collector) when full of water.

ROOF AREA FOR INSTALLATION

Roof area required for 2.0m² solar collectors:

- 3 solar collectors – 3.4 m wide x 2.0 m deep Weight (full) up to 102 kg approx.
- 2 solar collectors – 2.3 m wide x 2.0 m deep Weight (full) up to 82 kg approx.

In addition to this area, a minimum one (1) metre clearance is recommended on all four sides of the solar collectors for safe service access.

Maximum Number of Collectors

The maximum number of solar collectors for each tank size as part of an open circuit system is:

Non-Selective Surface 2.0m² Collectors – L collector

- 270, 320 tanks – 3 x collectors

Selective Surface 2.0m² Collectors – LCS, CSA2007 collectors

- 270, 320 tanks – 2 x collectors

ORIENTATION OF SOLAR COLLECTORS

The optimum orientation of solar collectors, to maximise system performance, is facing true north (in the southern hemisphere) or true south (in the northern hemisphere).

However, the optimum orientation of solar collectors is not always practical or achievable. If it is not possible to achieve the optimum orientation, then it is recommended to install the solar collectors as close to the optimum orientation as possible.

The total solar radiation received by solar collectors will reduce by approximately 4% to 5% when facing 45° from the optimum orientation and approximately 10% to 15% when facing 90° from the optimum orientation.

L or LCS or CSA2007 solar collectors may be installed up to 90° from the optimum orientation when installed as part of this system, however solar system performance will be reduced. Where the orientation is greater than 60° from the optimum, it may be possible for an additional L solar collector to be installed or to install selective surface collectors in lieu of non-selective surface collectors to make up for the reduction in solar performance.

Each of these options should be discussed with the system owner. If neither of these options is possible nor acceptable to the system owner, then the system owner needs to be made aware of, understand and accept that solar system performance will be reduced and increased boosting may be required to meet their hot water requirements.

Where the collectors can be installed at a similar angle either east or west of the optimal orientation, then the hot water load and usage pattern may need to be considered. If the majority of hot water usage is before 2:00 PM favour an easterly bias. If the majority of hot water usage is after 2:00 PM favour a westerly bias.

Note: Always check for true north or true south using a compass or other suitable device.

Refer to “Solar Collectors” on page 47 for additional information on the selection of type of solar collectors for this system.

INCLINATION OF SOLAR COLLECTORS

To help maximise system performance, solar collectors should be installed with an optimum inclination. This is equal to 90% to 100% of the local latitude angle when collectors are oriented within 60° of true north or true south, and between 10° and 20° when the collectors are oriented between 60° and 90° from the optimum orientation.

Generally, improved summer performance is obtained from an angle of inclination less than the optimum angle and improved winter performance is obtained by an angle of inclination greater than the optimum angle. If the angle of inclination varies by 20° from the optimum angle, the solar collectors will receive about 10% less total annual solar radiation. The [latitude of some Australian cities](#) are listed on page 50.

AS/NZS 3500.4 states that solar collectors shall be installed at an angle within 20° of the local latitude angle.

However, the optimum inclination of solar collectors is not always practical or achievable. Solar collectors may be installed at the roof angle for simplicity of installation and appearance, but must never be flat for a pumped solar water heater installation. Although the solar collectors can be installed with an inclination of less than 10°, this is not advised.

The risks include:

- the collector glass not 'self-cleaning', leading to dirty collector glass reducing solar performance, and
- condensation on the underside of the glass taking longer to clear, and
- condensation droplets falling onto the absorber plate potentially causing discolouration. and

The collector kit is suitable for installations with an inclination of up to 45°. Where the solar collectors are installed at inclinations greater than 45°, a With Pitch frame is necessary. Refer to your local Solahart Dealer for details.

A Variable Pitch frame can be installed to increase the angle of inclination of the collectors used in a pumped solar water heater installation. This type of frame should be used if the roof pitch either varies by more than 20° from the optimum angle or is less than 10°.

The use of a Variable Pitch frame should be discussed with the system owner. If this option is neither possible nor acceptable to the system owner, it may be possible for an additional L solar collector to be installed or to install selective surface collectors in lieu of non-selective surface collectors to help make up for the reduction in solar performance compared to the optimum inclination. Each option should be discussed with the system owner.

If these options are neither possible nor acceptable to the system owner, then the system owner needs to be made aware of, understand and accept that solar system performance will be reduced and increased boosting may be required to meet their hot water requirements.

CYCLONIC OR HIGH WIND AREAS

For an installation of solar collectors on a roof in a cyclonic or high wind area, a suitable frame is required. Refer to your local Solahart Dealer for details.

LATITUDE OF SOME AUSTRALIAN CITIES

Adelaide	35°S	Cairns	17°S	Hobart	42°S	Port Hedland	20°S
Alice Springs	24°S	Canberra	35°S	Mildura	34°S	Rockhampton	24°S
Brisbane	27°S	Darwin	12°S	Melbourne	38°S	Sydney	34°S
Broken Hill	31°S	Geraldton	28°S	Perth	32°S	Townsville	19°S

PIPE LENGTHS

The solar hot and solar cold pipes between the solar storage tank and the solar collectors shall:

- be of bendable grade or hard drawn copper tube, or annealed copper tube.

Annealed copper tubing shall not be joined using olive compression fittings.

Note: When annealed copper pipe is used in the collector circuit, then a suitable length of bendable grade or hard drawn copper pipe is to be brazed to the end of the collector circuit pipe work at the connection points where a copper or brass olive and compression nut is used. This requirement is to ensure there is minimum risk of pipe movement where the copper or brass olive and compression nut seal the connection at the fitting, so leaks will not occur.

- have a continuous fall from the solar collectors to the solar storage tank. Horizontal runs of pipe work are acceptable and may be installed as part of an open circuit system.

Care must be taken to ensure the pipe work maintains a continuous fall or horizontal runs over the life of the installation. Pipe work should be fixed at regular intervals to assist in maintaining this requirement. Particular care is to be taken when annealed copper tube is used to ensure this requirement is met.

- not exceed the maximum recommended combined lengths as specified in the table.

Maximum recommended total combined pipe length (solar hot + solar cold) and number of 90° bends				
Pipe Size	1 or 2 Collectors		3 Collectors	
	Pipe Length	90° Bends	Pipe Length	90° Bends
DN15	40 metres	20	30 metres	20
DN20	NR	NR	40 metres	20

For each additional 90° bend, reduce the maximum total pipe length by 0.5 metres.

For each additional metre of pipe length, reduce the number of 90° bends by two.

Note: One 90° elbow is equal to two 90° bends.

NR – not recommended.

It is essential for these requirements to be followed for the system to operate correctly and efficiently. Solar pipe work which is oversized, or is too long, or does not have a continuous fall can result in a reduction in performance or the system not operating effectively.

Notes

- It is important to connect the solar hot and solar cold pipes to the correct connections at the solar collector and at the solar storage tank.
- The solar cold pipe connects to the bottom of the solar collector array and may connect to either the left or right hand side. The solar hot pipe must connect to the top of the solar collector array diagonally opposite to the solar cold pipe connection. The solar hot outlet and hot sensor connection is to be the highest point of the system.
- The hot sensor connection is at the solar hot outlet where the solar hot pipe connects to the solar collector for this open circuit system.
- Refer to “Warning: Plumber – Be Aware” on page 52.

Maximum Height to Collectors

The maximum height of an open circuit solar Streamline installation, from the solar controller (circulator) to the top of the solar collectors, is determined by the maximum recommended total pipe length for the system and the water supply pressure. Refer to “Pipe Lengths” on page 50.

The maximum recommended total pipe length of the collector circuit should not be exceeded and a minimum water supply pressure of 200 kPa should be available at the inlet to the system, otherwise the system performance may be reduced or the collector circuit may not be purged of air during the commissioning of the system.

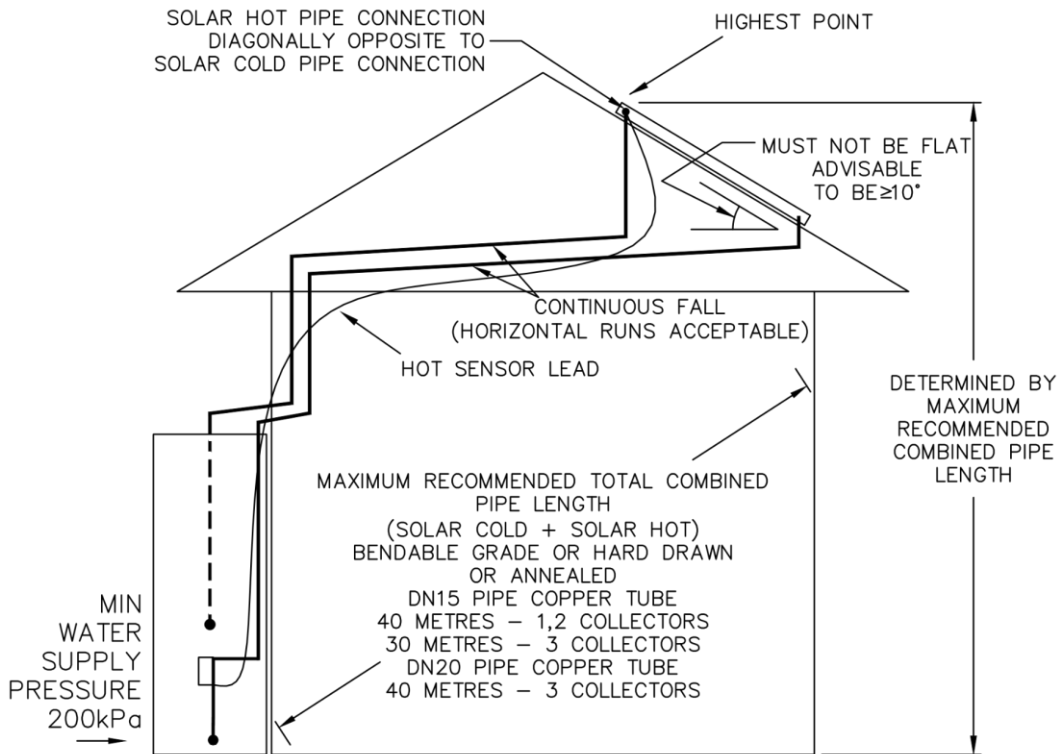

NOTES:

- PIPE WORK MUST HAVE A CONTINUOUS FALL FROM THE SOLAR COLLECTORS TO THE SOLAR STORAGE TANK. HORIZONTAL PIPE RUNS ARE ACCEPTABLE, AND MAY BE INSTALLED.
- PIPE WORK MUST BE OF BENDABLE GRADE OR HARD DRAWN COPPER TUBE, OR ANNEALED COPPER TUBE (CONDITIONS APPLY – REFER TO INSTALLATION INSTRUCTIONS).
- MINIMUM WATER SUPPLY PRESSURE TO INSTALLATION MUST BE 200kPa.
- INSTALL HOT SENSOR LEAD WITH INSULATED SOLAR PIPES DURING CONSTRUCTION FOR NEW HOMES.
- PRESSURE TESTING OF SOLAR COLLECTORS AND SOLAR CIRCUIT MUST NOT EXCEED 1000KPa.

Open Circuit System – Pipe Work Installation Requirements



WARNING: Plumber – Be Aware – Solar Installation

- The solar hot and solar cold pipes between the solar storage tank and the solar collectors **MUST BE** of copper. All compression fittings must use brass or copper olives.
- The full length of the solar hot and solar cold pipes **MUST BE** insulated.

The insulation must:

- be of a closed cell type or equivalent, suitable for a solar water heating application and capable of withstanding the temperature of the water generated by the solar collectors under stagnation conditions

The specification of the chosen insulation material should be checked with the insulation manufacturer prior to installation as different materials may vary in temperature tolerance.

- be at least 13 mm thick
- be weatherproof and UV resistant if exposed
- extend through any penetrations in the eaves, ceiling and roof
- cover valves and fittings in the solar pipe work
- be fitted up to and cover the connections on both the solar storage tank and the solar collectors.

Note: Failure to observe these requirements also increases the risk of freeze damage.

Uninsulated pipe work, including concealed in cavities and roof spaces or where it may be in contact with a metal roof, may lead to freeze damage. There is NO WARRANTY for freeze damage if the solar hot and solar cold pipes are not insulated in accordance with the installation instructions.

The insulation is essential to assist in providing freeze protection, will offer protection to a metal roof against corrosion due to water running off the copper pipes, assist in avoiding accidental contact with the solar pipe work as very high temperature water can flow from the solar collectors to the solar storage tank, and also reduce pipe heat losses.

- The insulated copper pipe work:
 - should be fixed at suitable locations to prevent or reduce the possibility of noise from water hammer and vibration from occurring
 - is not to be placed or installed in contact with plastic pipe work.

Likewise, plastic pipe work is not to be placed or installed in contact with the insulated copper pipe work after the collector circuit is installed.

- Plastic pipe **MUST NOT** be used, as it will not withstand the temperature and pressure of the water generated by the solar collectors under stagnation conditions. Extremely high water temperatures of up to 150°C for non-selective surface collectors and greater than 200°C for selective surface collectors and high water pressures exceeding 1000 kPa can be generated under these conditions. Plastic pipe cannot withstand these temperatures and pressures and **MUST NOT** be used. Failure of plastic pipe can lead to the release of high temperature water and cause severe water damage and flooding.
- The solar hot outlet and hot sensor connection is to be the highest point of the system. The highest point of the solar hot and solar cold pipes must be where they connect to the solar collectors, to avoid the possibility of air locks occurring in the system. There **MUST BE** a continuous fall in the pipe work from the solar collectors to the solar storage tank. Horizontal runs of pipe work are acceptable and may be installed as part of an open circuit system.
- The pressure applied to the collector circuit and solar collectors during a pressure test of an open circuit system **MUST NOT** exceed 1000 kPa, otherwise damage may result. Refer to “**Pressure Testing**” on page 53.

Pressure Testing

The solar water heater, including the collector circuit, is to be isolated during the testing and commissioning of the heated water reticulation system in a building in accordance with Clause 9.3 (a) of AS/NZS 3500.4:2021. The collector circuit includes the solar hot and solar cold pipes and solar collectors.

It may be necessary to pressure test the collector circuit to comply with codes and regulatory authority requirements or on other occasions where the solar collectors and solar hot and solar cold pipes are installed prior to the solar storage tank, such as on a building site.

Note: If the collector circuit is pressure tested prior to the installation of and connection to the solar storage tank, drain the solar collectors and collector circuit completely after the pressure test. Use an air compressor to drive all of the water out and if necessary, cap the ends loosely to prevent vermin ingress and allow air pressure build up to escape.

Collector Circuit

⚠ Warning: The pressure applied to the collector circuit during a pressure test of an open circuit system **MUST NOT** exceed 1000 kPa where L, LCS or CSA2007 solar collectors are installed, otherwise damage may result.

Open Circuit System

If the solar collectors, solar pipe work and solar storage tank are installed and commissioned together, then the flooding of the collector circuit with water under mains pressure for an open circuit system and checking the pipe work for leaks during the commissioning procedure can be substituted for the pressure testing of the collector circuit.

CONNECTIONS – PLUMBING

All plumbing work must be carried out by a qualified person and in accordance with the requirements of AS/NZS 3500.4 and all local codes and regulatory authority requirements.

Note: This water heater should not be installed as part of a circulated hot water flow and return system in a building. The benefits of either a controlled electricity supply or solar gain will be significantly reduced. If a circulated flow and return system is required, refer to “[Circulated Hot Water Flow and Return System](#)” on page 35.

CONNECTION SIZES

- Hot water connection: Rp 3/4
- Cold water connection: Rp 3/4
- Relief valve connection: Rp 1/2
- Solar hot (from collector) connection:
DN15 compression fitting to Service valve – (solar hot inlet to tank: Rp 3/4)
- Solar cold (to collector) connection:
DN15 compression fitting to pipe at circulator outlet – (solar cold outlet from tank: Rp 3/4)
- Solar service valve drain connection: DN15 compression fitting

WATER INLET AND OUTLET

All pipe work must be cleared of foreign matter before connection and purged before attempting to operate the water heater. All olive compression fittings must use brass or copper olives. Use an approved thread sealant such as Teflon tape on all sealing threads. Conetite or O-ring fittings do not require a thread sealant.

An isolation valve and non-return valve must be installed on the cold water line to the water heater. An acceptable arrangement is shown in the diagram. Refer also to “[Hot Water Delivery](#)” on page 34 and to “[Mains Water Supply](#)” on page 31.

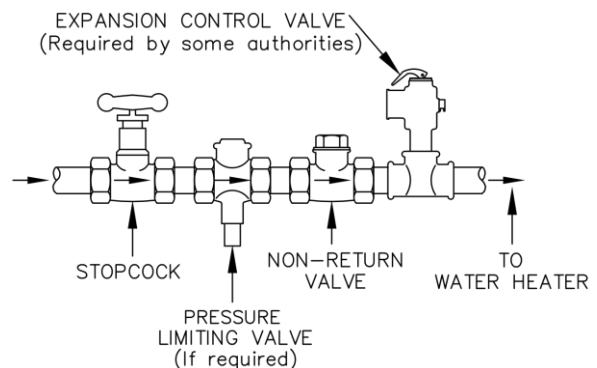

The plumbing arrangements for the [solar hot and solar cold pipes](#) as part of a solar water heater installation are shown on page 44.

A disconnection union must always be provided at the cold water inlet and hot water outlet on the water heater to allow for disconnection of the water heater.

This water heater has either a plastic diffuser, dip tube or fitting liner in the inlet and outlet fittings (see diagram). These must be in place for the water heater to function properly. Do not remove or damage them by using heat nearby. They will be pushed into the correct position as the fitting is screwed in.

This water heater is intended to be permanently connected to the water mains and not connected by a hose-set. A braided flexible hose or semi-flexible connector may be used for connection to the water heater, where permitted by AS/NZS 3500.4.

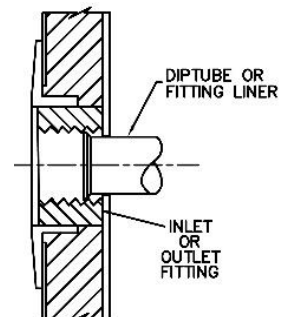

SOLAR CIRCUIT WATER CONNECTIONS

The water heater has two connections for the solar circuit, one located on the left hand side above the cold water inlet and the other on the lower right hand side opposite the cold water inlet. If the water heater is installed as an electric water heater, than these connections are to be plugged and capped. A kit is supplied with the water heater for this purpose.

The kit contains:

- 2 x 3/4" brass plugs
- 2 x plastic caps
- 2 x insulation rubber discs, pre-fitted into plastic caps

Plugging or Capping Off Unused Connections

- Apply approved sealing tape or compound to the thread of each plug.
- Fit the 3/4" plugs to the unused solar circuit fittings. Tighten the plugs using a 3/8" square driver.
- Fit a plastic cap with its insulation rubber disc over each plug.

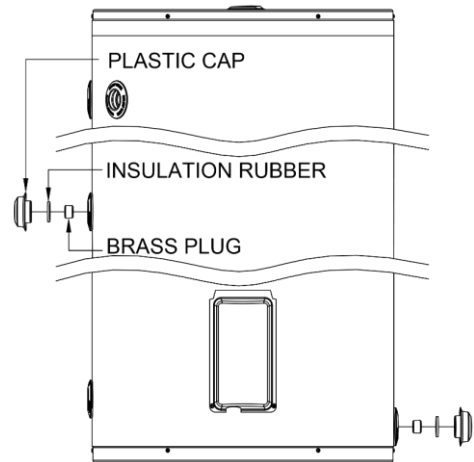

plugging and capping solar circuit fittings

PIPE MATERIAL

⚠ Warning: Certain types of plastic pipe, such as polybutylene pipe, are not suitable to be used as a hot water pipe between:

- this water heater and a temperature limiting device, and
- this water heater and a hot water outlet if a temperature limiting device is not installed.

This water heater, when installed as a solar water heater, can produce water at a temperature and pressure which can exceed the performance limits of these types of pipe. This may result in pipe failure leading to severe water damage to the property. If one of these types of plastic pipe is used as a hot water pipe in the property, then a temperature limiting device must be installed between the water heater and this pipe work.

PIPE SIZES

To achieve true mains pressure operation, the cold water line to the water heater should be the same size or bigger than the hot water line from the water heater.

The pipe sizing for hot water supply systems should be carried out by persons competent to do so, choosing the most suitable pipe size for each individual application. Reference to the technical specifications of the water heater and local regulatory authority requirements must be made.

IN-SERIES BOOSTER (IF INSTALLED)

The pipe work between the solar storage tank and an in-series booster has a minimum recommended pipe size of DN20 and **MUST BE** of copper unless a braided flexible hose is provided with a solar water heater connections kit for this purpose.

The pipe work shall be fully insulated with a closed cell type insulation or equivalent in accordance with the requirements of AS/NZS 3500.4. The insulation must be weatherproof and UV resistant if exposed. The insulation must be fitted up to the connections on both the solar storage tank and the in-series booster. The braided flexible hose provided with a solar water heater connections kit shall be insulated with the insulation provided.

An isolation valve may be installed on the on the solar preheat water line to the in-series booster. The isolation valve must be of a full flow type if the in-series booster is a continuous flow water heater.

TEMPERATURE PRESSURE RELIEF VALVE

The temperature pressure relief valve is shipped either under the top flap of the water heater carton or behind the front cover. The temperature pressure relief valve must be fitted before the water heater is operated. Before fitting the relief valve, make sure the probe has not been bent.

To fit the relief valve:

- Seal the thread with an approved thread sealant such as Teflon tape - never hemp. Make sure tape does not hang over the end of the thread.
- Hand tighten the valve into the opening marked "Relief Valve" (refer to the [installation diagrams](#) on pages 40 and 41).
- Using a spanner engaged on the valve's spanner flats and applying medium pressure to tighten, turn the relief valve an additional ½ to 1 ½ turns to secure and make the joint water tight, leaving the valve drain pointing downwards.

⚠ Warning: Do not use a pipe wrench or poor fitting tool on the valve body nor over tighten the valve, as this could damage the valve and prevent safe operation.

- Operate the easing lever on the valve to check the smooth operation of the valve plunger. It is very important the lever is raised and lowered gently. The lever should move smoothly and without undue force.
- If the lever cannot be moved or is jerky in its movement, then the valve has been damaged and must be replaced.
- A copper drain line must be fitted to the temperature pressure relief valve (refer to ["Relief Valve Drain"](#) on page 56).
- The valve must be insulated with closed cell polymer insulation or similar (minimum thickness 9 mm) and the insulation installed so as not to impede the operation of the valve.

The insulation must be weatherproof and UV resistant if exposed.

EXPANSION CONTROL VALVE

Local regulations may make it mandatory to install an expansion control valve (ECV) in the cold water line to the water heater. In other areas, an ECV is required if the saturation index is greater than +0.4 (refer to ["Water Supplies"](#) on page 22).

The expansion control valve must always be installed after the non-return valve and be the last valve installed prior to the water heater (refer to [diagrams on page 54](#)). A copper drain line must be fitted to the expansion control valve (refer to ["Relief Valve Drain"](#) on page 56).

The valve, if installed within 500 mm of the water heater, must be insulated with closed cell polymer insulation or similar (minimum thickness 9 mm) and the insulation installed so as not to impede the operation of the valve. The insulation must be weatherproof and UV resistant if exposed.

RELIEF VALVE DRAIN

DN15 copper drain lines must be fitted to the temperature pressure relief valve and expansion control valve (if one is installed). Connect the drain lines to the valves using disconnection unions. The drain line from the valve to the point of discharge should be as short as possible, have a continuous fall all the way from the water heater to the discharge outlet and have no tap, valves or other restrictions in the pipe work.

A drain line from a relief valve must comply with the requirements of AS/NZS 3500.4.

A drain line must be no longer than nine (9) metres with no more than three bends greater than 45° before discharging at an outlet or air break. The maximum length of nine (9) metres for a drain line is reduced by one (1) metre for each additional bend required of greater than 45°, up to a maximum of three additional bends. Where the distance to the point of final discharge exceeds this length, the drain line can discharge into a tundish.

Subject to local regulatory authority approval, the drain lines from the temperature pressure relief valve and expansion control valve from an individual water heater may be interconnected.

The outlet of a drain line must be in such a position that flow out of the pipe can be easily seen, but arranged so discharge will not cause injury, damage or nuisance. The termination point of a drain line must comply with the requirements of AS/NZS 3500.4. Drain lines must not discharge into a safe tray.

In locations where water pipes are prone to freezing, drain lines must be insulated, must not exceed 300 mm in length and are to discharge into a tundish through an air gap of between 75 mm and 150 mm.

If a drain line discharges into a tundish, the drain line from the tundish must be not less than DN20. The drain line from a tundish must meet the same requirements as for a drain line from a relief valve.

⚠ Warning: As the function of the temperature pressure relief valve on this water heater is to discharge high temperature water under certain conditions, it is strongly recommended the pipe work downstream of the relief valve be capable of carrying water exceeding 93°C. Failure to observe this precaution may result in damage to pipe work and property.

SERVICE VALVE DRAIN – SOLAR HOT INLET

A copper drain line must be fitted to the service valve drain outlet using the compression nut and olive provided with the valve. The drain line must carry the discharge safely to drain, clear of the water heater and solar control unit. The pipe work from the service valve to the drain should be as short as possible and fall all the way from the valve with no restrictions. Use DN15 pipe.

The outlet of the drain line must be in such a position that flow out of the pipe can be easily seen – but arranged so water discharge will not cause splashing, nuisance, damage or injury. Water discharged from the outlet of the drain line can be of a high temperature and under certain conditions, boiling or steaming.

⚠ Warning: The solar collectors can generate very high temperature water and even steam can be generated under certain conditions when the service valve is opened.

It is recommended the drain line be fully insulated with closed cell polymer insulation or similar (minimum thickness 13 mm). The insulation must be weatherproof and UV resistant if exposed. It is also recommended pipe work downstream of the service valve be capable of carrying boiling water. Failure to observe this precaution may result in damage to pipe work and property.

CONNECTIONS – ELECTRICAL

The power supply to the water heater must not be switched on until the water heater is filled with water and a satisfactory megger reading is obtained.

All electrical work and permanent wiring must be carried out by a qualified person and in accordance with the Wiring Rules AS/NZS 3000 and all local codes and regulatory authority requirements.

WATER HEATER POWER CONNECTION

The water heater must be directly connected to a 220 V - 240 V a.c. 50 Hz mains power supply with an isolating switch installed at the switchboard. It must be on its own circuit with the circuit breaker suitably rated for the booster heating unit.

The Wiring Rules AS/NZS 3000:2018 requires a second and lockable isolating switch be installed adjacent to but not on or attached to the water heater, and a residual current device (RCD) installed in the electrical circuit to the water heater.

The second and lockable isolating switch and RCD may not be required if the installation of this water heater tank is considered a repair under Clause 1.9.3.2 of the Wiring Rules, i.e., the installation of the water heater tank is a straight change-over and with a straight disconnect / reconnect of the wiring and where there is no modification to the electrical wiring of the final subcircuit or no increase in electrical load above the circuit capacity.

Connection to the water heater: The connection for the power supply wires for each water heater type is:

- **Electric Water Heater Installation – behind the LOWER front cover.**
- **Solar Water Heater Installation – behind the UPPER front cover.**

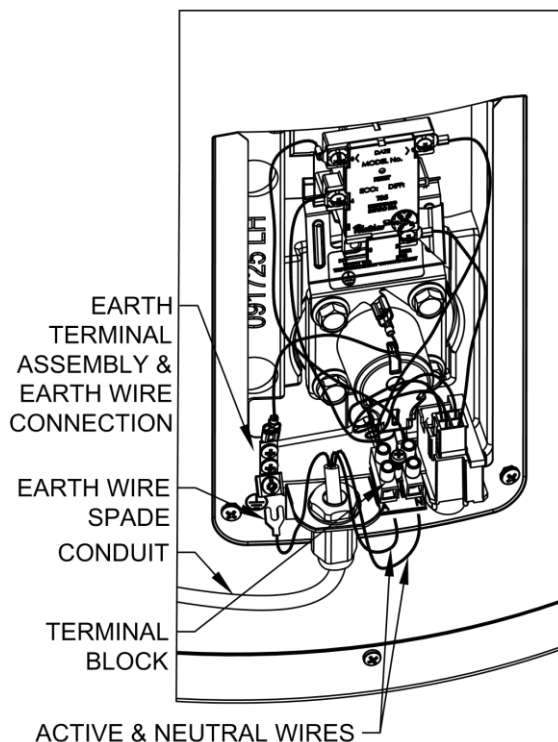

**Electric Water Heater – Lower Opening
Electrical Connection**

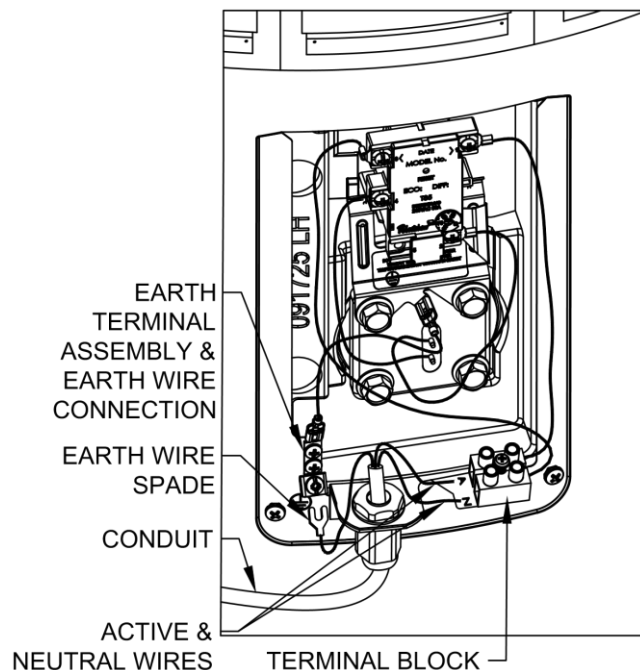

**Solar Water Heater – Upper Opening
Electrical Connection**

Connect the power supply wires directly to the terminal block and earth tab connection, ensuring there are no excess wire loops inside the front cover. The temperature rating of the power supply wires insulation must suit this application, or the wiring protected by insulating sleeving with an appropriate temperature rating if it can make contact with the internal storage cylinder. The temperature of the internal storage cylinder can reach 75°C under normal operation and up to 80°C could be reached during solar over-temperature operation.

A flexible 20 mm conduit is required for the electrical cable to the water heater. The conduit is to be connected to the unit with a 20 mm terminator.

Standard electric water heater (single heating unit): The power supply to this water heater can be either an Off-Peak (overnight), Extended Off-Peak (overnight and day) or Continuous / Domestic Time of Use electricity supply. An Off-Peak (overnight) power supply will provide the maximum financial savings.

Solar water heater (booster heating unit): The water heater is more suited for the booster heating unit to be connected to either a Continuous / Domestic Time of Use, or an extended Off-Peak (overnight and day) electricity supply. A timer can also be used to control the boosting periods and help maximise solar savings. Refer to “Booster Control” on page 61. The booster heating unit may be connected to an Off-Peak (overnight) electricity supply, however this will only allow the booster to heat the water overnight. If this type of connection is considered, care must be taken to ensure there is sufficient boost capacity to meet the household’s full day and night’s hot water supply during periods of no or low solar gain, particularly in cold weather.

THERMOSTAT SETTING

The water heater has two thermostats, which are adjustable from 60°C to 70°C. A thermostat is adjusted by turning the adjuster anticlockwise to decrease the temperature setting and clockwise to increase the temperature setting. Only adjust the temperature setting when the isolating switch is switched off at the switchboard.

The thermostat under the upper front cover controls the electricity supply to the top heating unit, which is the booster heating unit in a solar water heater installation. The factory setting of the thermostat is 60°C. For a solar water heater installation, it is recommended the top thermostat is left set at 60°C to maximise solar contribution.

The thermostat under the lower front cover controls the electricity supply to the bottom heating unit, which is the heating unit for a standard electric water heater installation. The factory setting of the thermostat is 70°C.

For reasons of safety and economy, we advise the thermostat be set at the lowest temperature that will provide sufficient hot water. Discuss the thermostat setting requirements with the householder.

SOLAR WATER HEATER INSTALLATION – ADDITIONAL INFORMATION

The power consumption of the solar water heater is:

Component	Power consumption	Comments
Solar controls	4 Watts	Constant load - differential controller
Solar circulator	36 Watts	Maximum load at solar heating cycle start up
	30 Watts	Average load during the solar heating cycle
Booster (top) heating unit	3600 Watts	Load when booster heating unit is operating
Anti-freeze (bottom) heating unit	1030 Watts	Load when frost heating unit is operating

The water heater will only operate on a sine wave at 50 Hz. Devices generating a square wave cannot be used to supply power to the water heater.

If this water heater is installed as a solar water heater with an in-series booster, then the electric booster heating unit will not need to be connected to a power supply and the references to the electric booster heating unit, thermostat and boosting controls in these installation instructions will not be applicable to the installation.

Note: AS 3498 requires that a water heater provides the means to inhibit the growth of Legionella bacteria in potable water. This water heater can satisfy this AS 3498 requirement provided, where an in-series booster water heater is not installed, the electric booster is energised for a sufficient period each day and the electric booster thermostat setting is 60°C or higher.

Solar Control Unit

The solar control unit, supplied with a 1.8 metre power cord, requires a switched 220 V - 240 V a.c. 50 Hz general purpose outlet (GPO) to be located within 1.2 metres of the installation. The GPO must have a continuous power supply originating from a circuit other than the water heater circuit. The GPO is required to be weatherproof if installed outdoors.

The GPO to the solar control unit must be switched on for the solar control system to operate and solar gain to be achieved. This includes for the circulating freeze protection function and anti-freeze heating unit to operate.

The solar control unit automatically controls the flow rate through the collector circuit. This is achieved via the hot and cold sensors and differential controller programming providing control over the operation of the circulator. There is no provision for nor is adjustment to the solar control unit required.

A flexible 20 mm conduit is provided for the electrical cable wiring harness from the solar control unit to the solar storage tank. The conduit's connector is to be connected to the tab of the electrical opening by sliding it into the two grooves on the tab and is locked in position by the lower front cover supplied with the solar control unit kit.

Connector 4 Pin connection – The 4 pin connector plug for the electrical connection to the 4 pin connector of the electrical cable wiring harness is behind the lower front cover located at the bottom of the tank.

Earth, Active, Neutral wire connections – The Earth wire of the solar controller cable is to be connected to the earth tab and the Active and Neutral wires of the solar controller cable are to be connected to the terminal block behind the lower front cover.

For the procedure to connect the wiring harness and conduit to the solar storage tank, refer to **“To connect the solar controller wiring harness and conduit to the solar storage tank”** on page 45.

⚠ Warning: Risk of Electric Shock – The connection of the solar controller wiring harness and conduit to the solar storage tank must be completed before unwrapping the cover from the power plug and inserting the plug into the socket-outlet.

Power to the solar control unit must only be switched on after the solar controller wiring harness and conduit has been connected to the solar storage tank and the solar water heater system has been filled with water. Refer to **“To Fill And Turn On The Water Heater”** on page 63.

New Lower Front Cover and Fitted Grommet

A new lower front cover is supplied in the solar control unit kit. This cover must replace the lower front cover on the solar storage tank when the electrical cable wiring harness from the solar control unit is connected to the tank.

The new lower front cover contains a grommet fitted in the left hand opening at the bottom underside of the cover. This opening is not used and the grommet must be left in position to maintain the IP rating of the solar storage tank.

Frost Element

The anti-freeze heating unit, rated at 1030 watts, is located behind the lower front cover and is supplied with power from the power outlet via the solar control unit. The power outlet to the solar control unit must be switched on for the anti-freeze heating unit to operate and offer additional freeze protection.

The anti-freeze heating unit is one blade of a unique triple blade heating unit with three element blades. The wiring of the 4 pin connector plug and 4 pin connector on the solar controller cable allows for the operation of one element blade only, which is rated at 1030 watts.

The temperature setting on the thermostat connected to the anti-freeze heating unit does not need to be adjusted as this thermostat does not provide temperature control. Its primary function is to provide an energy cut-out in the event the solar controller fails to turn off power to the anti-freeze heating unit. Temperature control for the freeze protection function is provided by the differential controller in the solar control unit.

⚠ Warning: If at any stage the heating unit requires replacement, the correct replacement triple blade heating unit must be used and it's rating must not exceed 1030 watts. Fitting a heating unit with a power rating greater than 1030 watts will damage the differential controller in the solar control unit, which would not be covered by warranty.

Booster Control

The isolating switch(s) installed at the switchboard and adjacent to the solar storage tank (if installed) should be left switched on. Leaving the isolating switch(s) switched on will also provide a sufficient period of time each day for the booster heating unit to operate, if required, to satisfy the requirements of AS 3498.

Timer Control Switch

A suitably rated timer control switch can be installed and will help maximise energy savings with an electrically boosted solar water heater connected to a **continuous, time of use or extended Off-Peak (overnight and day)** electricity supply.

If used with an extended Off-Peak (overnight and day) electricity supply, the timer switch should:

- be operated by a continuous power supply on its own circuit from the switchboard with the booster heating unit operated by the Off-Peak power supply.

A double pole isolating switch is required to be installed at the switchboard to simultaneously isolate both circuits.

or

- be of a type which has an internal rechargeable battery to keep time when the power supply is not available to the timer.

Refer to “**Booster Control**” on page 17 for information on programming the timer.

WIRING DIAGRAM – TIMER CONTROL SWITCH

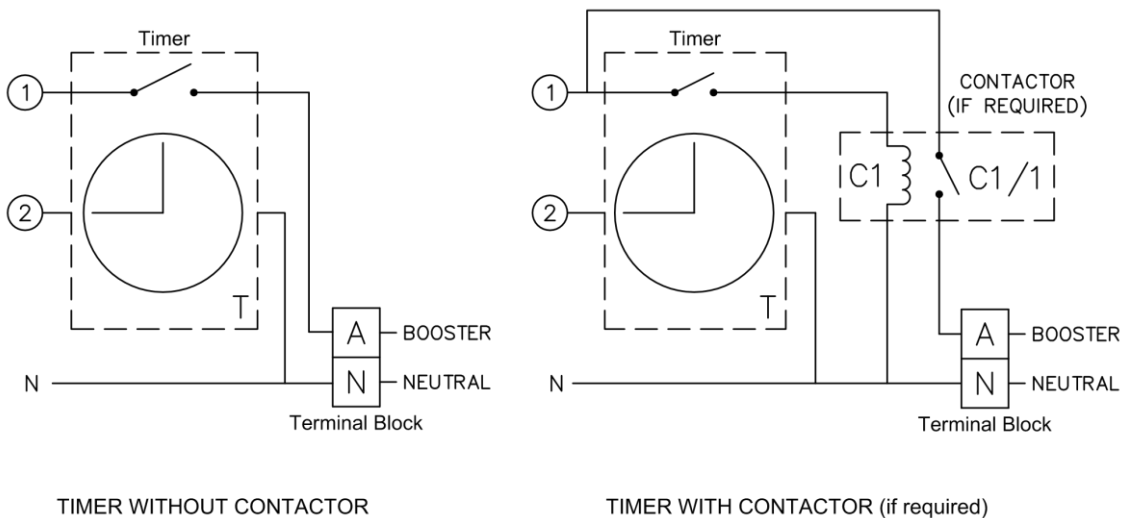
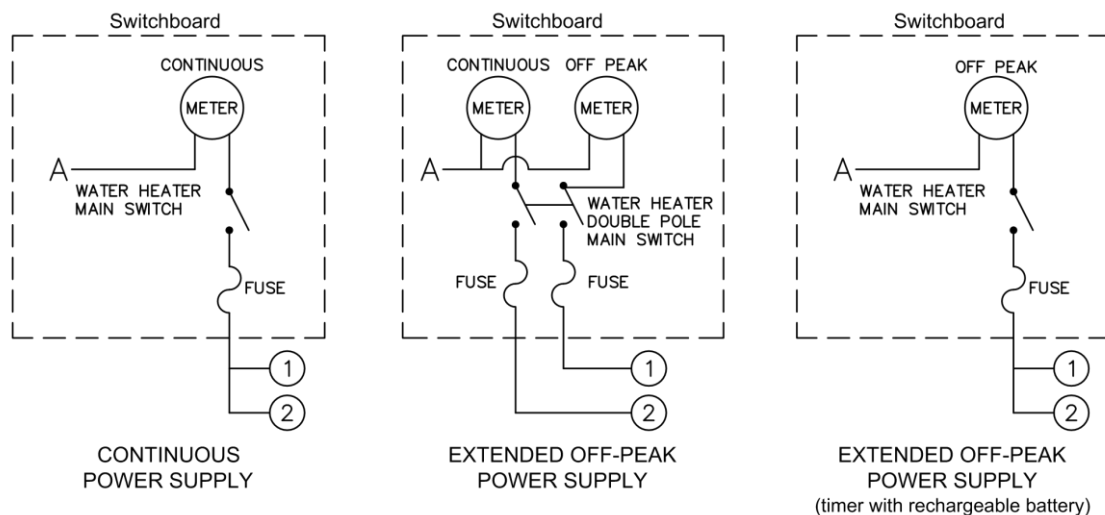

WIRING DIAGRAM – STANDARD ELECTRIC WATER HEATER

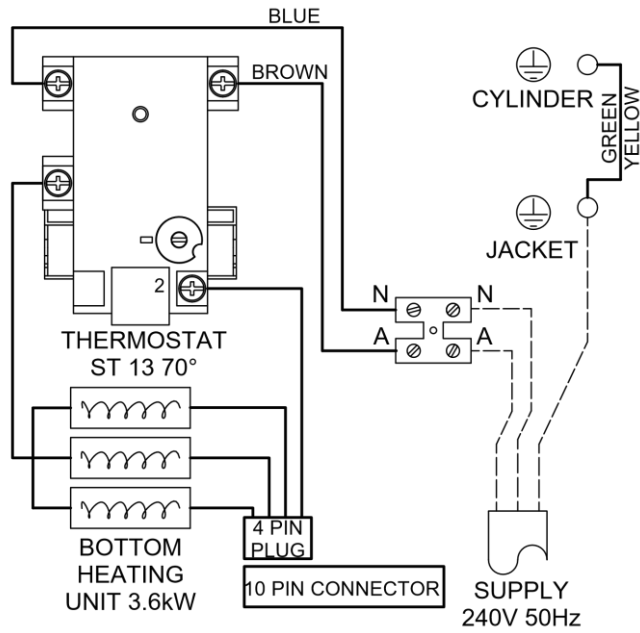

Bottom Opening of Standard Electric Water Heater

WIRING DIAGRAM – SOLAR STORAGE TANK

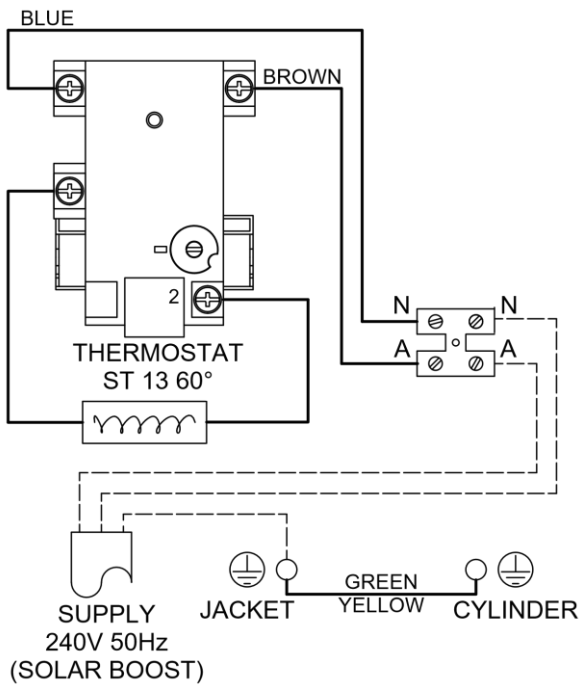

Top Opening of Solar Storage Tank

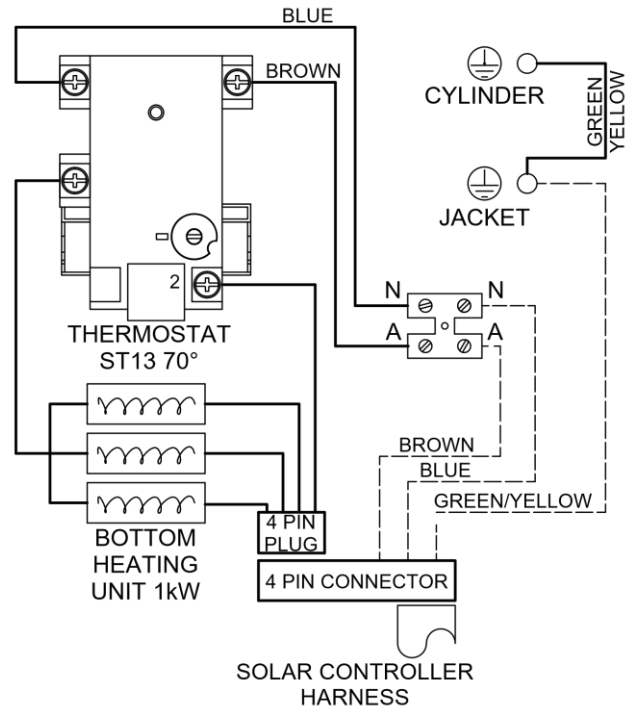

Bottom Opening of Solar Storage Tank

COMMISSIONING

TO FILL AND TURN ON THE WATER HEATER

The power supply to the solar storage tank and solar control unit must not be switched on until the water heater is filled with water and a satisfactory megger reading is obtained.

- Open all of the hot water taps in the house (don't forget the shower).
- *Solar installation:* Open the service valve fitted at the solar hot water inlet (from collector) of the solar storage tank, using a pair of pliers or other appropriate tool.

Refer to the [Service 3-Way Valve diagram](#) on page 64.

- Open the cold water isolation valve fully on the cold water line to the water heater.

Air will be forced out of the taps and the service valve drain line.

- Close each tap as water flows freely from it.
- *Solar installation:* Close the service valve when water runs freely from the drain line.

The solar collectors and collector circuit should now be purged of air.

- Check the pipe work for leaks.
- Inspect for leaks at the temperature pressure relief valve connection to the water heater.

If a leak is detected, close the cold water isolation valve fully and relieve pressure from the water heater by either operating the easing lever on the temperature pressure relief valve or opening a hot tap. Remove the valve and all of its thread sealant from the threads of the valve. Reapply new thread sealant and refit the valve.

Refer to the procedure in ["Temperature Pressure Relief Valve"](#) on page 56.

- Operate the easing lever on the temperature pressure relief valve to check the smooth operation of the valve plunger and that water discharges freely from the drain line. It is very important the lever is raised and lowered gently. The lever should move smoothly and without undue force.

If the lever cannot be moved or is jerky in its movement, then the valve has been damaged and must be replaced.

- *Solar installation:* Check the wiring harness and conduit from the solar controller has been connected to the solar storage tank.

⚠ Warning: Risk of Electric Shock – The connection of the solar controller wiring harness and conduit to the solar storage tank must be completed before unwrapping the cover from the power plug and inserting the plug into the socket-outlet.

- *Solar installation:* Plug in the solar control unit at the power outlet and switch on the electrical supply.

Power to the solar control unit must only be switched on after the solar controller wiring harness has been connected to the solar storage tank.

The power outlet must be switched on for the solar control unit to operate and solar gain to be achieved, for the circulating freeze protection to be available and the anti-freeze heating unit to operate and offer additional freeze protection.

Refer to ["Solar Controller Operation at Start-Up"](#) on page 65.

Note: The solar control unit automatically controls the flow rate through the collector circuit. This is achieved via the hot and cold sensors and differential controller programming providing control over the operation of the circulator. There is no provision for nor is adjustment to the solar control unit required.

- Switch on the electrical supply at the water heater isolating switch on the switchboard and at the isolating switch at the water heater (if installed).
- *Solar installation:* Set the timer if one is installed. Refer to ["Booster Control"](#) on page 61.
- *Solar installation:* Remove the packaging / covers from the solar collectors.

Note: *Solar installation:* If the service 3-way valve was not opened during the tank filling procedure above, then the collector circuit will need to be purged of air. Refer to ["Bleeding the Solar Collectors"](#) on page 64.

Explain to the householder or a responsible officer the functions and operation of the water heater and the timer if one is installed. Upon completion of the installation and commissioning of the water heater, leave this guide with the householder or a responsible officer.

TO TURN OFF THE WATER HEATER

If it is necessary to turn off the water heater on completion of the installation, such as on a building site or where the premises is vacant, then:

- Switch off the electrical supply at the water heater isolating switch on the switchboard and at the isolating switch at the water heater (if installed).
- *Solar installation:* Switch off the electrical supply to the solar control unit at the power outlet (refer to note below).
- Close the cold water isolation valve at the inlet to the water heater.

Notes

- The freeze protection system will be rendered inoperable if electrical power is not available at the solar control unit. Damage caused by freezing due to no power at the solar control unit is not covered by the Solahart warranty.
- If there is a risk of freezing, then it is necessary to drain the solar collectors and solar hot and solar cold pipes (refer to “**Draining the Solar Collectors**” on page 68).
- Refer to “**Terms of the Solahart Warranty**” on page 4.

BLEEDING THE SOLAR COLLECTORS

Upon completion of the installation, if the service 3-way valve was not opened during the tank filling procedure, then it is necessary to purge the air from the collector circuit.

To purge air from the collector circuit:

- Ensure the water heater is full of water and all of the hot taps are turned off.
- Using a pair of pliers or other appropriate tool, open the service 3-way valve fitted at the solar hot water inlet (from collector) of the solar storage tank (see diagram).

Warning: Stand well aside of the service valve drain pipe discharge point and exercise care to avoid any splashing of water, as water or in some circumstances steam discharged from the solar collectors may be of a very high temperature.

- The mains pressure will force water to flow from the tank and through the pipe work, forcing air from the collector circuit through the service valve. This is evidenced by spurting of water from the drain line connected to the service valve.

Note: Allow water to flow from the drain line for a few minutes before closing the service valve. Water already in the solar hot pipe will drain out prior to air in the top of the collector circuit being purged by the mains pressure water rising in the solar cold pipe.

- Close the service valve when water runs freely under mains pressure from the drain line.

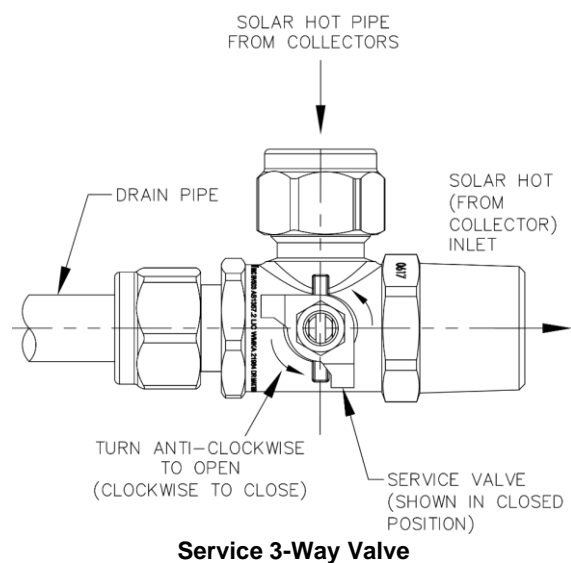

SOLAR CONTROLLER OPERATION AT START-UP

When the electrical supply is switched on to the solar control unit at start-up:

- If there is no solar gain, the circulator will not activate and the green LED will emit a slow pulse.

The slow pulse indicates the circulator is not activated and the power to the solar control unit has been on for less than 48 hours.

- If there is solar gain, the circulator activates and the green LED will emit a series of three (3) flashes.

The three (3) flashes indicate the circulator is operating and power to the solar control unit has been on for less than 48 hours.

- The circulator will operate at full speed for approximately fifteen (15) seconds.

After fifteen (15) seconds, the solar controller will commence to pulse the circulator to reduce the flow rate through the collector circuit. This will increase the temperature rise across the solar collectors and assist in maximising the system efficiency for the available solar energy. It is normal operation for the circulator to experience a pulsing effect.

- The red LED may emit a rapid pulse for a short period (whilst the green LED is emitting a series of three (3) flashes), particularly if the solar collectors were left uncovered during the final stages of the installation and commissioning procedure.

This indicates a temperature difference between the hot sensor and cold sensor of greater than 45°C and does not represent a fault code. This is the result of a build-up of heat and increase in water temperature in the solar collectors prior to the switching on of the electrical supply to the solar control unit.

The rapid pulsing of the red LED will cease as the water circulates and the heat is dissipated from the solar collectors. This should be within four (4) to five (5) minutes of start-up, but may take up to ten (10) minutes

Whilst the red LED is emitting a rapid pulse, the circulator will operate at full speed. After the red LED has extinguished, the solar controller will commence to pulse the circulator to reduce the flow rate through the collector circuit.

If the red LED does continue to emit a rapid pulse for longer than ten (10) minutes, this may indicate water is not circulating through the solar collectors and collector circuit:

- switch off the electrical supply at the power outlet to the solar control unit
- repeat the procedure to bleed the solar collectors

Refer to **“Bleeding the Solar Collectors”** on page 64.

- switch on the electrical supply at the power outlet to the solar control unit.

DIAGNOSTIC FEATURES OF THE SOLAR CONTROLLER

A solar monitor is located on the side of the solar control unit and houses a green and a red LED.

The green LED, marked “Solar”, indicates the current operational mode of the solar water heater and the red LED, marked “Attention”, may indicate a potential fault mode.

The green LED will emit either a constant glow, a constant pulsing or a series of flashes, with a two (2) second interval between each series.

The red LED will emit either a constant glow, a constant pulsing or a series of flashes with a two (2) second interval between each series. A constant glow or pulsing does not necessarily mean there is a fault with the system. A series of flashes indicates there may be a particular fault condition with the system.

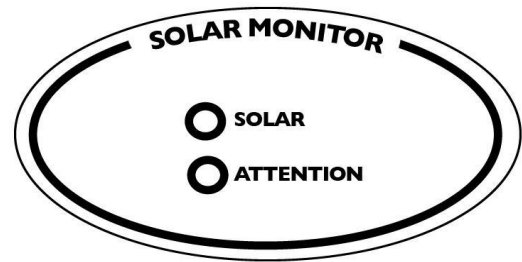

The modes are:

Flashes	Operational Modes
solid green (remains on)	Standby mode
green slow pulse	Standby mode (power on for less than 48 hours)
green rapid pulse	Circulating water through collectors
3 x green	Circulating water through collectors (power on for less than 48 hours)
no green (remains off)	Power outage or call for service

Flashes	Indicator or Fault Modes
solid red (remains on)	Hot sensor temperature greater than 130°C
red rapid pulse	Temperature rise across collector greater than 45°C (circulator at full speed)
3 x red	Hot sensor in collector – short circuit
4 x red	Hot sensor in collector – open circuit
5 x red	Cold sensor –short circuit
6 x red	Cold sensor – open circuit

If the power supply to the solar control unit is on and the green LED is off or the red LED is flashing, this indicates there may be a fault with the water heater. The red LED may emit from three (3) to six (6) flashes in each series of flashes. A constant glow or pulsing of the red LED does not necessarily mean there is a fault with the system.

Note: During periods of high solar radiation and if the circulator activates after having been off, such as during start-up if the solar collectors have not been covered, it is possible the red LED may emit a rapid pulse for a period of up to ten (10) minutes. This does not indicate a fault. Refer to “Solar Controller Operation at Start-Up” on page 65 for the possible green and red LED pulsing sequence during start-up procedure.

If the red LED continues to emit a rapid pulse for longer than ten (10) minutes, or emits a series of flashes, then count the number of flashes and phone your nearest Service Department or Accredited Service Agent to arrange for an inspection.

DRAINING THE ELECTRIC WATER HEATER

⚠ Warning: Exercise care, as water discharged from the water heater may be of a very high temperature.

To drain the water heater:

- Turn off the water heater (refer to **“To Turn Off The Water Heater”** on page 64).
- Close all hot water taps.
- Operate the relief valve lever - do not let the lever snap back or you will damage the valve seat. **It is very important the lever is raised and lowered gently.**

Operating the lever will release the pressure in the water heater.

- Undo the union at the cold water inlet to the water heater and attach a hose to the water heater side of the union.

Let the other end of the hose go to a drain.

- Open the relief valve by holding the lever in the raised position.

This will let air into the water heater and allow the water to drain through the hose.

DRAINING THE SOLAR STORAGE TANK

To drain the solar storage tank:

- Cover the solar collectors with an opaque material.
- Open a hot water tap and allow the water to run for five (5) minutes immediately prior to draining the solar storage tank.

This will assist in the transfer of any high temperature water in the solar collectors to the solar storage tank.

- Close the hot water tap.
- Turn off the water heater (refer to **“To Turn Off The Water Heater”** on page 64).

⚠ Warning: Exercise care, as water discharged from the solar storage tank may be of a very high temperature.

- Operate the relief valve lever - do not let the lever snap back or you will damage the valve seat. **It is very important the lever is raised and lowered gently.**

Operating the lever will release the pressure in the water heater.

- Undo the union at the cold water inlet and attach a hose.

Let the other end of the hose go to a drain.

- Open the relief valve by holding the lever in the raised position.

This will let air into the solar storage tank and allow the water to drain through the hose.

DRAINING THE SOLAR COLLECTORS

To drain the solar collectors and the solar hot and solar cold pipes:

- Cover the solar collectors with an opaque material.
- Open a hot water tap and allow the water to run for five (5) minutes immediately prior to draining the solar collectors.

This will assist in the transfer of any high temperature water in the solar collectors to the solar storage tank.

- Close the hot water tap.
- Turn off the water heater (refer to **“To Turn Off The Water Heater”** on page 64).

 **Warning:** Exercise care, as water discharged from the solar collectors may be of a very high temperature.

- Using a pair of pliers or other appropriate tool, open the service valve fitted at the solar hot water inlet (from collector) of the solar storage tank (refer to **diagram** on page 64).
- Undo the compression fitting on the union located to the right of the solar control unit, and disconnect the solar cold pipe.

Water will now drain from the solar collectors and the solar hot and solar cold pipes.

- When water stops flowing from the solar hot and solar cold pipes, reconnect the solar cold pipe to the circulator and tighten the compression fitting.
- Close the service valve.

PURGING AND FLUSHING THE SOLAR COLLECTORS

Upon completion of the installation, if the service 3-way valve was not opened during the tank filling procedure, then it is necessary to purge the air from the collector circuit.

Other than at the time of the water heater's installation, it will be necessary to purge air from the collector circuit:

- When the water heater is to be turned on and the solar collectors and solar hot and solar cold pipes have been drained.
- After maintenance has been conducted on the pipe work and air has entered the system.
- If the circulator appears not to be circulating water around the system.

It is also recommended to flush the solar collectors every five (5) years. This will assist in keeping the solar collectors, and solar hot and solar cold pipes clear of sediment.

It may also be necessary to flush the solar collectors if there is sediment in the water supply.

⚠ Warning: Other than at the time of the water heater's installation, it is recommended purging air from the collector circuit or flushing of the solar collectors be conducted early in the morning, within three (3) hours of sunrise, when the sun is low in the sky. The water temperature inside the solar collectors is lower as the solar collectors would not have had a chance to gain as much heat as later in the day. Purging air from the collector circuit or flushing the solar collectors at a time later than this can result in the discharge of high temperature water and in some circumstances, high temperature steam.

To purge air from the collector circuit or flush the solar collectors:

- Open a hot water tap and allow the water to run for five (5) minutes.
- Close the hot tap.
- Wait a further five (5) minutes before attempting to purge air from the collector circuit or flush the solar collectors.

This will assist in the transfer of any high temperature water in the solar collectors to the solar storage tank.

⚠ Warning: Exercise care, as water discharged from the solar collectors may be of a very high temperature.

- Follow the procedure "**Bleeding the Solar Collectors**" on page 64, allowing the water to flow from the service valve drain line for a few minutes before closing the service valve.

This page is intentionally blank.

This page is intentionally blank.

This page is intentionally blank.



SOLAHART INSTALLATION REPORT

Dear Customer

A copy of this installation report is to be attached to an STC Assignment Form (where applicable) as proof of installation. This may be applicable where this Electric Solar Ready Water Heater is installed as part of a solar water heater installation. It can be copied and kept for your records. An electronic version may be provided by the Dealer instead.

Installer, please complete all details below

Owner's Name							
Installation Address							
Suburb				Telephone Home			
State				Work			
Postcode				Mobile			
Email Address							
Dealership / Agent				No. of Stories of Install		Single	Other
Installer's Name				Installation Date			
Type of Installation (please circle)	Replace Complete Solar System	Replace Solar Tank	Replace Electric or Gas	Replace Heat Pump	New Building	New Install on Existing Building (not replacing a unit)	Other
System Model No				System Type			
Tank Model No				Tank Serial No			
Collector Model No				No of Collectors			
Collector Serial No's	1)	2)	3)	4)			
Electric Booster (please circle)	Electric continuous	Off Peak 1 (night)	Off Peak 2 (night & day)	Solar Preheat only			
Electric Booster Control (please circle)	None	Timer	Manual Switch	Other			
Gas Booster (if installed)	Model No		Serial No				

If replacing a water heater, please give details

Brand		Model No		Electric	Gas
If a Solahart unit	Tank Serial No		Date of manufacture		
Collector Serial No's	1)	2)	3)	4)	

Comments					

Signature:	Installer:	Customer:
Date		

This page is intentionally blank.

This page is intentionally blank.

SOLAHART OFFICES

International Headquarters

Solahart Industries Pty Ltd
(ABN 45 064 945 848)

Registered and Head Office
1 Alan Street
Rydalmere, New South Wales, 2116
Australia

Postal Address:
PO Box 7508
Silverwater, New South Wales, 2128
Australia

Principal Tank Manufacturing Facility
55 Brodie Street
Rydalmere, New South Wales, 2116
Australia

www.solahart.com.au

Australia

For SERVICE Telephone - **1800 638 011**
or your nearest Solahart Dealer

For Sales Telephone - **1300 769 475**
or your nearest Solahart Dealer

International Sales

Telephone International Sales:
+ 61 8 9351 4600

Facsimile International Sales:
+ 61 8 9351 4698

Email:
solahart@solahart.com.au

Web:
www.solahart.com